

# STUNNING VISUALS & CRYSTAL CLEAR SOUND



**Branch & Drop Co-axial Cables**

## THE FINOLEX GROUP

The Finolex Group is one of India's leading industrial groups and has interests spanning over several sectors. Finolex Cables Limited, an IS/ISO 9001 Certified Company, is the flagship company of Finolex Group and has its plants in Pimpri (Pune), Urse (Near Pune), Verna (Goa), and Roorkee(Uttarakhand). As India's leading manufacturer of electrical and communication cables, it offers Total Electrical Solution with products like various types of electrical cables with copper or aluminum conductor, Communication Cables, High Voltage and Low Voltage Power Cables, EC grade copper rods, Compact Fluorescent Lamps, T5 luminaries and fittings, LED Lightings and a wide range of Electrical switches serving the needs of sectors like construction, automotive, agricultural, communications, power and other industrial sectors.

### GAS INJECTED PHYSICAL FOAM CO-AXIAL CABLES

Finolex co-axial cables, RG11 & Drop - RG6/RG59 used for Cable TV networks, are designed for optimum performance and value for money. The arithmetic is very simple. The cables offer higher bandwidth, so your customers can receive the maximum number of channels with a high level of picture and sound quality. This translates to more happy customers, larger cable TV networks and more profits for the cable operators.

#### WORLD-CLASS DESIGN & TECHNOLOGY

- Nitrogen gas injected physical foam dielectric manufactured by using imported polyethylene. The gas injected foam is far superior to the chemical foam
- Stringent raw material, in-process and final testing ensures consistent quality which guarantees reliable and long-lasting performance
- UV and abrasion resistant outer jacket is of a special grade PVC compound in black colour that is formulated in-house using PVC resin manufactured by Group company - Finolex Industries Ltd.
- Cable is sequentially marked along the length at every metre
- Each length of the cable is 100% tested on an imported Hewlett Packard make high frequency computerised Network Analyser, for Attenuation, Impedance, and Structural Return Loss (SRL) up to 3 GHz Complete manufacturing of cable is done in-house on ultra-modern imported machinery

#### BRANCH & DROP CABLES

- Centre conductor of solid electrolytic grade 99.97% pure copper manufactured in house. Also RG11 cables are offered with Copper Clad Aluminum conductor and RG6 and RG59 are offered with Copper Clad Steel conductor.
- The First shield / Secondary conductor is made of a specially designed polyaluminium tape, bonded on the dielectric. The tape is applied with sufficient overlap longitudinally over the foam dielectric
- The Second shield is of imported aluminium alloy wire braiding with high tensile strength and has more than 60% coverage

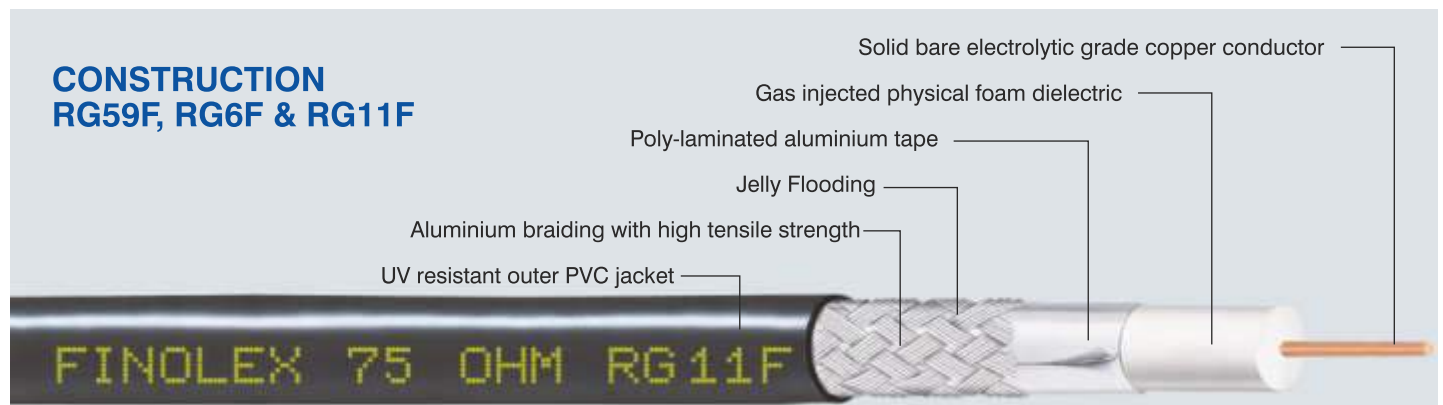

#### WHY FINOLEX CO-AXIAL CABLE ?

- Use of Electrolytic Grade Tough Pitch (ETP) Pure Copper for RG59, RG6 & RG11, manufactured in house
- Use of specially designed Al-Poly-Al bonded tape construction for secondary conductor for RG59, RG6 & RG11
- Use of Imported Foam material in Gas Injected Foaming
- Employs latest state-of-the-art Imported computerised Extrusion line with precision controls
- In-house formulated & manufactured special grade PVC compound
- Latest techniques used in Quality Control for raw material, In-Process & Final testing as per International Standards
- Testing of each Bobbin / Coil on computerised Test equipment for Attenuation, Impedance & SRL upto 3GHz
- Easy Identification for length with the help of non-contact Printing

# ADVANTAGES OF GAS INJECTED PHYSICAL FOAM DIELECTRIC OVER CHEMICAL FOAMING

- High foaming (upto 80%) which leads to lower attenuation
- No impurities in foam due to use of inert gas i.e. nitrogen
- Foam cell structure is uniform across entire length, ensuring consistent electrical parameters, in all batches
- No performance variation under extreme weather conditions
- Lighter weight & Longer life

PARAMETERS	DROP RG59 F	DROP RG6 F	BRANCH RG11 F
<b>A. CONSTRUCTION</b>			
1 Inner Conductor	Solid Bare Copper	Solid Bare Copper	Solid Bare Copper
2 Nominal Diameter (mm)	0.80	1.02	1.63
3 Dielectric	Foam PE	Foam PE	Foam PE
4 Nominal Diameter (mm) Outer Conductor	3.55	4.57	7.11
5 First	Bonded Al Tape	Bonded Al Tape	Bonded Al Tape
6 Second	Al Braid	Al Braid	Al Braid
7 Nominal Coverage (%)	60	60	60
8 Flooding Compound	Jelly	Jelly	Jelly
9 Jacket	PVC (Black)	PVC (Black)	PVC (Black)
10 Nominal Diameter (mm)	6.20	7.0	10.0
11 Bending radius, Minimum (mm)	65	65	75
<b>B. ELECTRICAL</b>			
1 Inner Conductor Solid Copper Maximum Resistance (Ohm/100m) at 20°C	3.55	2.13	0.84
2 Nominal Capacitance (pf/mtr.)	53	53	53
3 Nominal Impedance (Ohm)	75	75	75
4 Nominal Velocity Ratio (%)	85	85	85
<b>C. ATTENUATION (@ 20°C)</b>			
<b>FREQUENCY MHZ</b>	<b>dB/100m Max.</b>	<b>dB/100m Max.</b>	<b>dB/100m Max.</b>
55	6.73	5.20	3.15
83	8.04	6.20	3.87
187	11.81	9.15	5.74
211	12.47	9.50	6.23
250	13.45	10.50	6.72
300	14.60	11.50	7.38
350	15.75	12.45	7.94
400	16.73	13.30	8.53
450	17.72	14.35	9.02
500	18.70	14.95	9.51
550	19.52	15.70	9.97
600	20.34	16.45	10.43
750	22.87	18.35	11.97
865	24.67	19.95	13.05
1000	26.64	21.45	14.27

## Connectorisation Procedure



1. Cut jacket through to braid.



2. Remove jacket.



3. Fold back braid and cut through dielectric and tape.



4. Remove dielectric and tape.

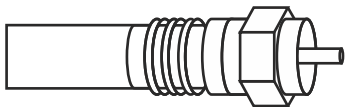

5. Slide on connector.

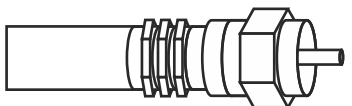

6. Crimp connector.

The empirical relationship between dielectric constant & foaming percentage :

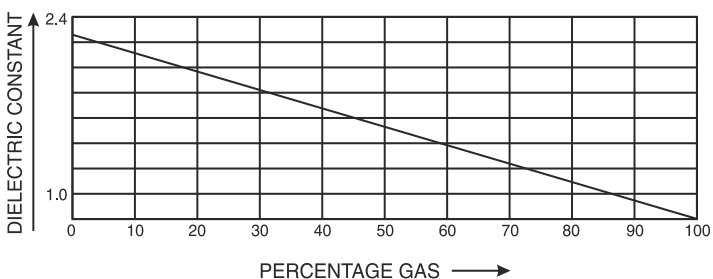

Comparison between distribution of bubbles in chemical & physical foaming process :

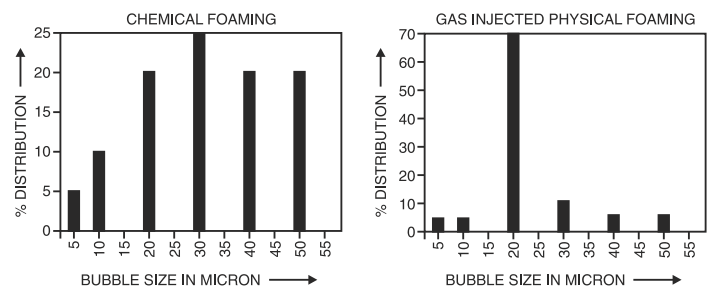

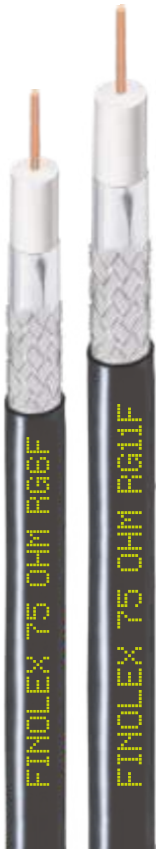

**World-class quality**  
**More than 100 channels**

### CO-AXIAL CABLES – DOs & DON'Ts

- Pulling tension: Inconsistent pulling results in jerks, leading to cable elongation and permanent impedance variation. 2% sag of tower height is advisable.
- Minimum bending radius: Proper bending to be maintained to avoid cable damage at the corner. It is 65 mm and 75 mm for RG59/RG6 and RG11 respectively.
- Expansion loops in the system: Loops to be installed, to prevent unrestrained movement at bends as well as at connector-cable interface.
- Lashing: Care to be taken that lashing is not very tight. Never use a naked GI wire as it may cut the cable at a later date. Proper lashing clamps should be used.

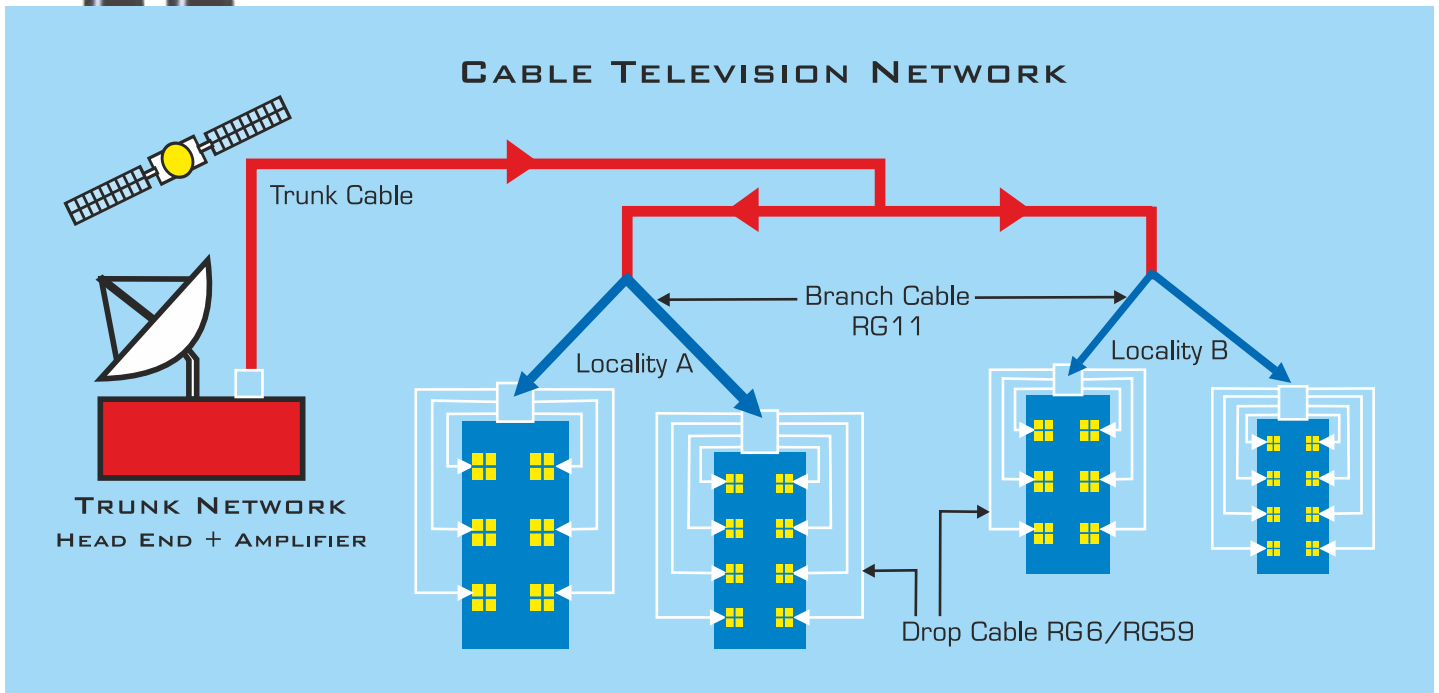

[/FinolexOnline](#) | [/FinolexOnline](#) | [/Finolex.Online](#)



**AN IS/ISO 9001 CERTIFIED COMPANY**

26-27, Mumbai-Pune Road, Pimpri, Pune - 411018, India  
 Tel: 020-27506200 | Fax: 020-27472239  
 Visit us at: [www.finolex.com](http://www.finolex.com) | Email: [sales@finolex.com](mailto:sales@finolex.com)  
 CIN: L31300MH1967PLC016531

**Finolex gets people together**

For technical literature please contact our Branch Offices:

**Ahmedabad:** Tel: 079-26584637, 26575639 | **Bangalore:** Tel: 080 25320176 |  
**Bhubaneshwar:** Tel: 0674-2530053 | **Chennai:** Tel: 044-28231514, 28284142 |  
**Chandigarh:** Tel: 0172-5076631, 2637334 | **Cochin:** Tel: 0484-2408930, 2408492 |  
**Coimbatore:** Tel: 0422-2333939/40 | **Dharwad:** Tel: 0836-2746440 | **Goa:** Tel: 0832-2782003, 2782065 | **Gurgaon:** Tel: 0124-4382304 | **Guwahati:** Tel: 0361-2490067 |  
**Indore:** Tel: 0731-2802646 | **Jaipur:** Tel : 0141-2332526/29 | **Kolkata:** Tel: 033-24192494, 24192495 | **Lucknow:** Tel: 0522-2439815, 4035031 | **Ludhiana:** Tel: 0161-2804005 | **Mumbai:** Tel: 022-22873252, 22820062 | **New Delhi:** Tel: 011-23324748, 23353160 | **Patna:** Tel: 0612-2589835 | **Pune:** Tel: 020-27475963, 27506200 | **Raipur:** Tel: 0771-2885595 | **Ranchi:** Tel: 0651-2284758 | **Roorkee:** Tel: 01332-224068 |  
**Secunderabad:** Tel: 040-27721224, 27811161 | **Vijayawada, Vadodara, Pondicherry.**

Sample card available on request

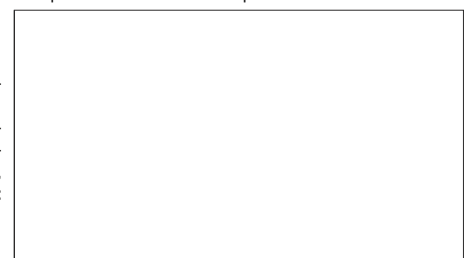

All information given herein is in good faith. Finolex shall not be liable for any damages arising out of incorrect use or interpretation. The Company reserves the right to change any of the above specifications without any prior notice.

*In order to derive maximum benefit and utilisation of our products, we advise that these products are stored, installed and commissioned as per the norms prevailing in the place of installation. When decommissioned, these should be disposed using appropriate methods/process specified in respective state / location of use so as not to affect the environment adversely.*

# FLAMEGARD



## FLAME RETARDANT LOW SMOKE HALOGEN (FR-LSH) PVC INSULATED INDUSTRIAL CABLES

- ✓ High-Temperature Index
- ✓ Low Acid Gas Generation
- ✓ Low Smoke Density
- ✓ High Critical Oxygen Index



XCEEDS EXPECTATIONS

# Finolex Cables Limited

Started in 1958, Finolex Cables Limited is India's largest and leading electrical and telecommunication cables manufacturer. Finolex Cables has always believed in enhancing capabilities and augmenting the product basket. In last few years, besides the cables business the company has forayed into new segments and added new products under the Finolex brand. The company offers Total Electrical Solutions with products like Electrical Wires, 3 Core Flat Cables, Communication Cables, Telecommunication Cables, Flexible Cables, Auto Cables, Conduits, Room Heaters, LED Lights, Switches, Switchgears, Fans, Irons and Water Heaters. Finolex Cables Limited has four manufacturing facilities viz. at Pimpri (Pune), Urse (near Pune), Verna (Goa) and Roorkee (Uttarakhand).

The company is known for their unmatched quality and safety standard which has made it amongst the most reliable brands of the country. Over the six-decade long journey, Finolex Cables has cemented its reputation as an innovative leader and quality manufacturer by continuously upgrading technology, modernizing manufacturing facilities and maintaining the highest standards in quality and service.

## Flamegard - Flame Retardant Low Smoke Halogen (FR-LSH) PVC Insulated Industrial Cables

Finolex is the first company to have introduced the Flame Retardant Low Smoke Halogen (FR-LSH) electrical wires in India. The conductor, with its class 5 flexibility as per IS 8130, is manufactured by using the electrolytic grade copper that offers superior conductivity. It is insulated with FR-LSH grade PVC compound, that is formulated and manufactured in-house. In case of fire, Flamegard wires have a special flame retardant, low smoke emitting, and toxic fumes suppressing properties, with improved fire performance for FR-LSH as per IS 694: 2010, backed by the latest amendments.

During a fire, an ordinary PVC insulated wire gives out thick and black smoke along with toxic fumes of hydrochloric acid gas. This impairs visibility and hampers rescue operations. Flamegard wires, on the contrary, not only emit very little smoke and toxic gases but also retards the spread of fire. It is thus ideal for concealed and conduit wiring in multistoried high-rise buildings such as hotels, banks, hospitals, factories, commercial and residential complexes, etc. where the density of people is high. Flamegard wires go through rigorous tests to ensure the highest standards of quality. For unique identification, these wires are provided with an orange stripe. Flamegard wires are manufactured in our state-of-the-art manufacturing plants at Urse (Near Pune), Verna (Goa) and Roorkee (Uttarakhand).

### FLAMEGARD - SINGLE CORE, UNSHEATHED CABLES IN VOLTAGE GRADE 1100V

Nominal area of copper conductor Sq. mm	Thickness of insulation (Nom.) mm	Approx. overall diameter mm	Current carrying capacity # 2 wires, single phase		Max. conductor resistance per km. @20° C Ohms
			In conduit / Trunking Amps	Unenclosed – clipped directly to a surface or on cable tray Amps	
0.75	0.6	2.30	6	7	26.0
1.0	0.6	2.50	11	12	19.5
1.5	0.6	2.70	13	16	13.3
2.5	0.7	3.30	18	22	7.98
4.0	0.8	4.00	24	29	4.95
6.0	0.8	4.50	31	37	3.30

Standard Colours: Black, Red, Blue, Yellow and Green (for earthing). # As per IS 3961 (Part V) - 1968

### THE FLAMEGARD ADVANTAGE

Test	Function	Test Method Specification	Typical Values	
			Flamegard Wires	Ordinary Pvc Insulated Wires
Critical Oxygen Index	To determine the percentage of oxygen required for supporting the combustion of insulating material at room temperature.	IS 10810 Part 58	More than 29%	23%
Temperature Index	To determine at what temperature the normal oxygen content of 21% in the air will support the combustion of the insulating material.	IS 10810 Part 64	More than 250°C	150°C
Acid Gas Generation	To ascertain the amount of hydrochloric acid gas evolved from the insulated wire under fire.	IS 10810 Part 59	Less than 20%	45-50%
Smoke Density Rating	To determine the density of smoke from the burning of the insulating material.	IS 13360 Part 6 / Sec 9	Maximum smoke density rating 60%	More than 60%

Also meets the requirements of the flammability test as per IS 694

## Flame Retardant V/s FR-LSH Electrical Wires

Electrical safety is a function of five characteristics viz. smoke, hazardous gas generation, rate of heat release, flame spread and the rate of burning. In case of a fire in a closed space, trapped people are unable to find the exit due to the emission of thick black smoke and loose consciousness due to the inhalation of toxic fumes before they can be evacuated to safety.

The advantage of low smoke and low acid gas generation is the additional and critical feature that is available with the Finolex FR-LSH Flamegard wires in comparison with FR (Flame Retardant) wires which do not provide these properties.

IS:694



CM/L-7306463  
CM/L-7525273  
CM/L-8944096

# Finolex Cables Limited

AN IS/ISO 9001 CERTIFIED COMPANY

26-27, Mumbai-Pune Road, Pimpri, Pune - 411018, India.  
Tel: 020-27506200 | Visit us at: www.finolex.com  
Email: sales@finolex.com  
CIN: L31300MH1967PLC016531

FOR TECHNICAL LITERATURE PLEASE CONTACT OUR BRANCH OFFICES: Ahmedabad : Tel: 079-26584637 / 26575639 | Bengaluru : Tel: 9845278680 | Bhubaneswar : Tel: 0674-2971188, 2971922 | Chennai : Tel: 044-28231514/28284141 | Chandigarh : Tel: 9316064670 | Cochin : Tel: 9880088155 | Coimbatore : Tel: 0422-2330997 | Dharwad : Tel: 9880088155 | Goa : Tel: 0832-2782003 / 2782065 | Gurgaon : Tel: 9896763770 | Guwahati : Tel: 9435324398 | Indore : Tel: 7314911723 | Jaipur : Tel: 9929111411 | Kolkata : Tel: 0522-4035031 | Lucknow : Tel: 9560299393 | Mumbai : Tel: 022 - 22820062 | New Delhi : Tel: 9870170171 | Patna : Tel: 9934107999 | Pune : Tel: 020 - 27506200 | Raipur : Tel: 7008336581 | Ranchi : Tel: 8101383841 | Secunderabad : Tel: 040 - 27811161 | Uttarakhand : Tel: 9760045003 | Vadodara : Tel: 9879555568 | Vijayawada : Tel: 9848043967

[f /finolexcables](#) [t /finolexcables](#) [i /finolex.cables](#)

ALL INFORMATION GIVEN HEREIN IS IN GOOD FAITH. FINOLEX SHALL NOT BE LIABLE FOR ANY DAMAGES ARISING OUT OF INCORRECT USE OR INTERPRETATION. In order to derive maximum benefit and utilisation of our products, we advise that these products are stored, installed and commissioned as per the norms prevailing in the place of installation. When decommissioned, these should be disposed using appropriate methods/process specified in respective state / location of use so as not to affect the environment adversely. While every effort has been taken to guarantee that all details and portrayals are correct, this leaflet should not be viewed as a definitive guide or as a proposal of sales for a specific product. Due to variable factors in the production process, shades of the actual product might fluctuate marginally from those portrayed. Model numbers and particulars are for reference purposes only. May subject to change without prior notice.

**Finolex**

**Empowering  
The Future, Together.**

**XCEEDS  
XPECTATIONS**



**POWER CABLES CATALOGUE**



## About Us

---

Started in 1958, Finolex Cables Limited is India's largest leading electrical and telecommunication cables manufacturer. Finolex Cables has always believed in enhancing capabilities and augmenting the product basket. In the last few years, besides the cables business, the company has forayed into new segments and added new products under the Finolex brand. The company offers complete electrical solutions with products like electrical wires, 3 core flat cables, communication cables, telecommunication cables, flexible cables, auto cables, copper rods, CFLS, led lighting range, electrical switches, switchgears, fans, and electric water heater range. Over the years, Finolex has established itself as an innovator and leader by constantly upgrading their technology, modernizing facilities, and maintaining the highest standards in quality services. Finolex Cables Limited has four manufacturing facilities viz. at Pimpri (Pune), Urse (near Pune), Verna (Goa), and Roorkee (Uttarakhand).

## Power Cables Solutions

---

Finolex has developed a special grade XLPE compounds Finvul-X and Finopower to be used as the insulating material suitable for LT and HT cables. The increasing demand of power voltage cables has necessitated the development of a cable insulant which has a combination of excellent di-electric properties, non-hygroscopic nature of polyethylene and higher operating temperature.

The XLPE (cross linked polyethelene) insulation meets all these necessary properties. Finopower XLPE insulated HT Cables and FINVUL-X LT Power Cables have excellent di-electric, thermal, mechanical and chemical properties.

**XCEEDS  
EXPECTATIONS**

# OUR PRODUCT RANGE



XCEEDS  
EXPECTATIONS

The various advantages of using **Finopower and FINVUL-X Cables** are given below:

- **Higher current rating:** Withstands continuous conductor temperature of 90°C higher current carry capacity
- **Higher short circuit rating:** Can withstand conductor temperatures of up to 250°C during a short circuit
- **Higher overload capacity:** These cables can operate even at 130°C. during emergency, unlike PVC cables which cannot operate beyond 120°C. Thus, in case of emergency, cables can withstand overload for a limited time duration
- Lighter in weight, smaller bending radius, the cables require less support, lower installation
- **Lower di-electric constant and power factor:** Doesn't cause power losses and hence results in saving costs
- Better impact, abrasion, corrosion
- Easier jointing and termination
- **Discharge free HT cable:** Negligible level of partial discharge values. We confirm PD value as < 1 pC (max), as against allowable limit of 5 pC as per IS 7098 Part 11/2011
- **True Triple Extrusion Line for HT cable:** (Not 1+2 Tandem Extrusion Line) with single cross head in a most modern CCV (Continuous Centenary Vulcanizing) plant
- Pre-heating of conductor of HT cables to remove the dust and moisture before extrusion for proper bonding between semicon and XLPE layers and also to avoid heat shock during extrusion
- Completely dry curing process for HT cables under inert gas (nitrogen) for a contamination and void free cable
- **SIKORA X-Ray:** Most modern online monitoring system for continuously measuring and controlling thickness of insulation, core diameter and eccentricity for a perfect HT cables with reduced stress levels
- Automatic pneumatic system for special contamination free material handling of insulating and semi-conducting compound in a dry and clinically clean environment for HT cables
- For HT cables, special internal check like microscopic inspection for imperfections in di-electric, optimization of curing of di-electric and check for bonding strength of semi-conducting layers with XLPE

### TYPICAL PROPERTIES OF XLPE INSULATION

Di-electric constant		2.35	IS:7098 (Part 1) IS:7098 (Part 2) 
Di-electric strength	kV/mm	22	
Volume resistivity at 27 °C	Ohm-cm	10 <sup>14</sup>	
Thermal resistivity	°C cm/W	350	
Power factor at maximum conductor temperature		0.008	
Nominal conductor operating temperature	c	90	
Emergency overload temperature	c	130	

### VOLTAGE GRADE

1. **LT - Up to and including 1100V**
2. **HT - Earthed System: 3.8/6.6 kV, 6.35/11 kV, 12.7/22 kV & 19/33 kV, 1.9/3.3 kV Unearthed System: 3.3/3.3 kV, 6.6/6.6 kV & 11/11 kV cables of 6.35/11kV grade (Earthed System) are suitable for use on 6.6/6.6 kV (Unearthed System)**

### CABLE SPECIFICATION

Finopower XLPE cables are manufactured and tested as per IS: 7098 (Part2): 2011.  
 Finvul-X XLPE cables are manufactured and tested as per IS: 7098 (Part1): 1988.

# TYPICAL CABLE CONSTRUCTION



- 1 PVC JACKET   
 2 INNER SHEATH   
 3 CONDUCTOR   
 4 ARMOURING   
 5 FINVUL-X INSULATION

As per IS: 7098 - (Part - 1): 1988 for working voltage up to and including 1100V

## CONDUCTOR

Conductors are made from electrolytic, grade highly pure aluminium and copper, conforming to IS 8130-2013 and are circular or compact circular / sector shaped. Up to 10 sq. mm conductor will be solid and above will be stranded.

## INSULATION

FINVUL-X cables are specially manufactured with high di-electric grade cross linked polyethylene for insulation and is applied by extrusion process.

## INNER SHEATH

Laid up cores are bedded over with thermoplastic material for protection against mechanical damage.

## PVC JACKET

Specially formulated heat resistant black PVC compound ST2 type as per IS 5831:1984 and is extruded to form the jacket. Finolex also offers specially formulated Flame Retardant (FR) / Flame Retardant Low Smoke (FRLS) compound for jacket used in fire hazardous environment.

## CORE IDENTIFICATION

The cores are identified by different colours :

Single core	Red/Natural	Two core	Red, Black
Three core	Red, Yellow, Blue	Three and half core	Red, Yellow, Blue and reduced neutral core in Black
Four core	Red, Yellow, Blue, Black	Five core	Red, Yellow, Blue, Black and Grey
Six core and above	Two adjacent cores (counting and direction core) in each layer Blue and Yellow, remaining cores Grey.		

## LAYING UP

In multicore cables, cores are laid up as per the above colour scheme.

## ARMOURING

Armouring is provided over the inner sheath to guard against mechanical damage. Armouring is generally of galvanised steel wires or strips. In single core cables, used in AC system, armouring is by non-magnetic hard drawn aluminium wires. Round steel wires are used where the diameter over the inner sheath does not exceed 13 mm, above 13 mm flat steel strip armour is used. Round wire of different sizes can also be provided against specific request.

## PVC JACKET

Specially formulated, heat-resistant black PVC compound ST2 type as per IS 5831:1984 and is extruded to form the jacket. Finolex also offers specially formulated Flame Retardant (FR) / Flame Retardant Low Smoke (FRLS) compound for jacket used in fire hazardous environment.

## TESTS

In addition to all tests required as per IS 7098 (Part I) 1988, FINVUL-X cables are subjected to a number of in-house tests at every stage of production. Incoming raw material is also tested thoroughly to ensure consistency of quality.

## PRODUCT CODE

As per IS 7098 (Part I) & (Part II), the codes are:

Constituent code	7098-1	7098-2
Aluminium conductor	A	A
Copper conductor	-	-
FINVUL-X insulation	2X	2X
Steel round wire armour	w	w
Steel strip armour	F	F
Steel double round wire armour	WW	WW
Steel double strip armour	FF	FF
PVC jacket	Y	Y
Copper tape/wire screening	-	CE
Non-magnetic round wire armour	Wa	Wa
Non-magnetic strip armour	Fa	Fa
Polyethylene outer sheath	-	2Y

## LENGTH

Finolex provides continuous length of 500 / 1000 meters  $\pm$  5% for single/multi-core armoured and unarmoured cables up to 400 sq.mm. Sizes above 400 sq.mm. are generally packed in 250 metres  $\pm$  5%. The cables are progressive sequentially marked on every 1 meter length for ease of length measurement.

## PACKING AND MARKING

FINVUL-X cables are wound on sturdy, non-returnable wooden drums built to withstand the weight of the cable as well as handling abuses. Each drum is marked with particulars required under IS 7098 (Part I) 1988. Steel drums can be offered on special request.

# FINOPOWER HIGH VOLTAGE CABLE CONSTRUCTION

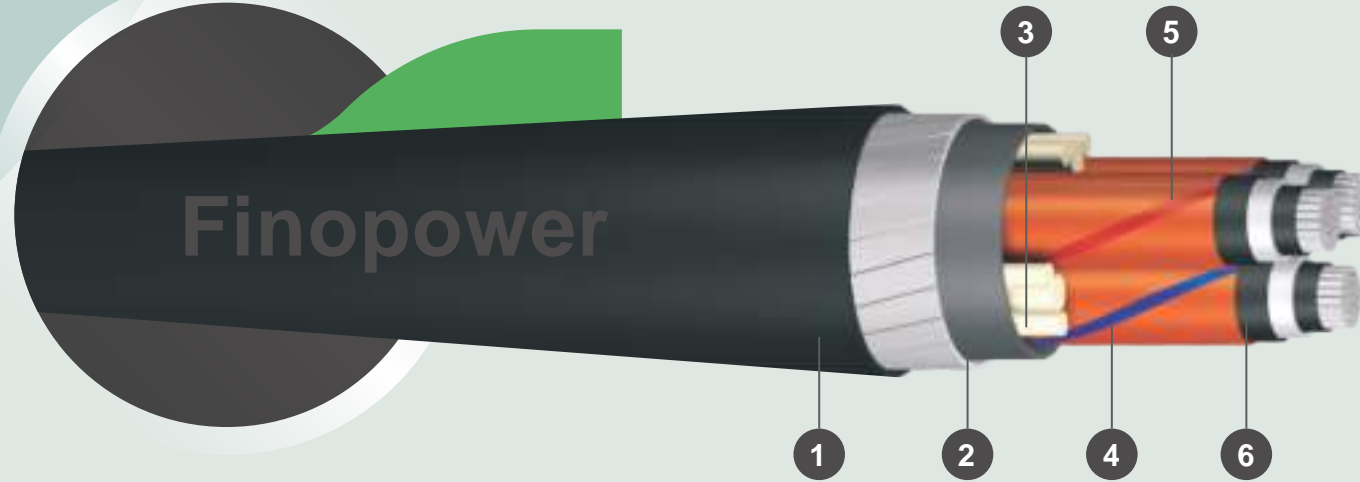

- 1 OUTER SHEATH
- 2 INNER SHEATH
- 3 NON-HYGROSCOPIC FILLER
- 4 CORE IDENTIFICATION COLOUR TAPE
- 5 COPPER TAPE SCREENING
- 6 EXTRUDED SEMI-CONDUCTING NON-METALIC INSULATION SCREENING

As per IS: 7098 - (Part - 2): 2011 for working voltage from 3.3 kV up to and including 33 kV

## CONDUCTOR

Conductor is made of electrolytic grade, high pure copper or aluminum, conforming to IS 8130 - 2013. The conductor is circular, stranded with high compactness and smooth surface finish.

## CONDUCTOR SCREENING

Each conductor is provided with an extruded layer of semi-conducting compound. This eliminates the chance of electrical discharge at the interface between conductor and insulation.

## INSULATION

The natural coloured XLPE compound with high dielectric strength is extruded over semi-conducting conductor screening with specified thickness in **contamination free climate. Cross linking is done by completely dry curing process.**

## INSULATION SCREENING

The insulated core is further extruded with a layer of semi conducting compound to form the nonmetallic part of insulation screening.

The conductor screening, XLPE insulation and the non metallic part of insulation screening are all extruded in one operation by a special process, **Triple Extrusion**. This process ensures perfect bonding between conductor screening and insulation screening with XLPE insulation. **This bond eliminates the formation of micro voids during extrusion and curing.** This ensures **longer cable life under worst operating conditions.** Non-magnetic copper tape is applied as metallic part of insulation screen over the non-metallic extruded part of the insulation screening.

## CORE IDENTIFICATION

The core identification for three core cables is done by coloured strips applied on the cores. The core identification also offered with core numbering tapes as per requirement of customers.

## LAYING UP

Three cores are laid up together to form the cable. The interstices are filled up with non-hygroscopic type fillers, to make the cable circular.

## INNER SHEATH (COMMON COVERING)

The three core laid up cable is provided with a common covering of wrapped plastic tape/s or by an extruded PVC inner sheath, as per the requirement of customer.

## ARMOURING

Armouring is applied over the inner sheath in case of three core cables. For single core cables it is applied over non-metallic part of insulation screening. Three core cables have either galvanised round steel wire or galvanised steel strip armour, conforming to IS 3975-1999. Single-core cables are armoured with hard drawn round aluminum wires. For mining and other special applications, double wire / strip armoured cables can also be offered.

## OUTER SHEATH

The cables are provided with outer sheath of tough heat-resisting PVC compound, type ST 2 as per IS 5831-1984. The outer sheath is extruded over armouring in case of armoured cables. For single core unarmoured cables, outer sheath is extruded over the non-magnetic metallic part of insulation screening. Outer sheath in general is of black colour.

## QUALITY ASSURANCE AND TESTING

**Finopower** cables are manufactured by using latest state of art machinery and testing facilities, guided by experienced and highly qualified engineers and technologists.

At Finolex quality is ensured throughout the manufacturing process. The quality checks are performed starting from raw material, right through every stage of manufacturing to the final testing. The SQC techniques are applied at various critical stages of manufacturing to ensure the consistency of quality.



For maintaining the highest quality, Finolex cables have developed special internal additional checks. Some of the special checks conducted are as under:

- Microscopic inspection for imperfections in the di-electric
- Degree of cross-linking of the di-electric
- Bonding strength of semi-conducting layers with insulation



**Finolex CCV (Continuous Catenary Vulcanisation) line is equipped with most modern new generation X-Ray type diameter controller for measuring, monitoring and controlling of thickness, diameter and eccentricity throughout the length.**

The cables are tested in accordance with IS: 7098 (Part 2) - 2011 & IS 7098 (Part 1) 1988.

The following routine tests are carried out on every length of cable manufactured:

- Conductor resistance test
- Partial discharge test (applicable for HT cables)
- High-voltage test



## HIGH-VOLTAGE TEST

The following test voltages are applied between conductors and screen / armour.

Voltage rating of cable	Test voltage
1.1 kV	3 kV (rms) for 5 minutes
1.9/3.3 kV	10 kV (rms) for 5 minutes
3.3/3.3 kV	10 kV (rms) for 5 minutes
3.8/6.6 kV (E)	13 kV (rms) for 5 minutes
6.6/6.6 kV (UE)	21 kV (rms) for 5 minutes
6.35/11kV (E)	21 kV (rms) for 5 minutes
11/11kV (UE)	35 kV (rms) for 5 minutes
12.7/22 kV (E) I	42 kV (rms) for 5 minutes
19/33 kV (E)	63 kV (rms) for 5 minutes

In order to meet consistency in quality, the cables manufactured undergo stringent quality checks at each stages from raw material to finished cable. These cables also undergo stringent physical, dimensional and other checks for conformity to the required standards. At Finolex, chemical and electrical laboratories are of the highest standard, possessing the most modern equipments for precision testing and quality control.

## LONGER PACKING LENGTH

As per special requirements of the customers, the cables can **also be offered with longer lengths** other than standard packing length. The **Finopower** and **FINVUL-X** Cables are **provided with progressive sequential length marking** on outer jacket. The cables are also offered with FR/FRLS properties, as given in the adjoining table. The conductor details, insulation thickness, dimension, weight and packing data along with electrical parameters are furnished in the respective tables.

# FINVUL-X AND FINOPOWER FLAME RETARDANT (FR)/ FLAME RETARDANT CABLES WITH REDUCED HALOGEN EVOLUTION AND SMOKE (FR-LSH)

Test	Functions of the test	Specification	Specified values	Applicable for
Critical oxygen index	To determine the percentage of oxygen required for supporting combustion of sheathing material at room temperature	ASTM - D - 2863 IS: 7098 - I & II	Min. Oxygen Index of 29%	FR & FR-LSH
Temperature index	To determine at what temperature oxygen content in air will support combustion of sheath material	ASTM - D - 2863 BICC Hand Book chapter no. 6 IS: 7098 - I & II	Min. Temperature Index of 250°C at 21% oxygen	FR & FR-LSH
Smoke destiny	To determine the destiny of smoke from the burning of sheath material	ASTM - D - 2843 IS: 7098 - I & II	Smoke density rating shall be 60% max.	FR-LSH
Acid gas generation	To ascertain the amount of Halogen Acid Gas evolved during combustion of sheath material	IEC - 60754 -1 IS: 7098 - I & II	Max. Halogen Acid Gas released 20% by weight	FR-LSH
Flammability test on group of cables	To determine flame propagation of cables in installed conditions	IEEE - 383	In total 20 minutes of burning the 8 feet long cable samples at a temperature of 1500°F the burning of cables shall not go up to the top	FR-LSH
Flammability test	1) To determine ignition resistance and flame propagation underspecified conditions.	1) Swedish Standard No. SS 4241475 Class F3 IS: 7098 - I & II	1) From test sample of 850 mm length, the unburnt portion shall be more than 300 mm from the top.	FR-LSH
	2) To determine ignition resistance and flame propagation underspecified conditions.	2) IEC 332 - 1 IS: 7098 - I & II	2) Period of burning after removal of flame shall not exceed 60 sec and unaffected portion from the lower edge of the top clamp shall be at least 50 mm.	FR & FR-LSH
	3) To determine ignition resistance and resistance to flame propagation, especially for bunch of cables, underspecified conditions.	3) IEC 332 - 3 IS: 7098 - I & II	3) From the test samples of 3.5 m length, the affected portion during burning, shall not reach 2.5 m or above from the bottom edge of the burner.	FR & FR-LSH



## RATING FACTORS

For installation conditions other than the standard conditions specified above, rating factors have to be applied as given in relevant tables.

**Electrical parameters of the cables furnished in tables are based on the following assumptions:**

Maximum permissible conductor temperature for continuous operation	Aluminium 90°C	Copper 90°C
Ambient air temperature	40°C	40°C
Ground temperature	30°C	30°C
Thermal resistivity of soil	1.5 k.m/w	1.5 k.m/w
During short circuit max temp	250°C	250°C
Specific gravity	2.703 g/cm <sup>3</sup>	8.89 g/cm <sup>3</sup>
Resistivity at 20°C	28.264 0 mm <sup>2</sup> /km	17.241 0 mm <sup>2</sup> /km
Specific heat	0.22 cal/gm/°C	0.093 cal/gm/°C
Temperature coefficient of resistance at 20°C	0.00403/°C	0.00393/°C

# 1.0 TECHNICAL DATA FOR 1100V LT CABLES

**TABLE 1.1: FINVUL - X 1100 V Grade Single Core, Aluminium Conductor, XLPE Insulated, Unarmoured/Armoured, PVC Type ST-2 Jacketed Cables**

Norn. Cross Sectional Area Sq.mm	Unarmoured				Armoured						Max. DC Conductor Resistance at 20°C Ohm/km	A.G. Current Rating			
	Norn. Thickness of XLPE Insulation mm	Norn. Thickness of Outer Sheath mm	Approx. Overall Dia. mm	Approx. Cable Weight kg/km	Norn. Thickness of XLPE Insulation mm	Norn. Dia of Alu. Wire for Armour mm	Min. Thickness of Outer Sheath mm	Approx. Overall Dia. mm	Approx. Cable Weight kg/km	In Air		In Ground			
										2 Cables Amps		3 Cables Amps	2 Cables Amps	3 Cables Amps	
10	0.70	1.80	9.70	106	1.00	1.4	1.24	12.10	176	3.08	64	55	69	59	
16	0.70	1.80	10.70	134	1.00	1.4	1.24	13.20	211	1.91	84	72	89	76	
25	0.90	1.80	12.30	185	1.20	1.4	1.24	14.80	276	1.20	112	98	115	98	
35	0.90	1.80	13.40	223	1.20	1.4	1.24	15.90	321	0.868	137	119	137	116	
50	1.00	1.80	15.00	277	1.30	1.4	1.24	17.50	387	0.641	165	145	161	137	
70	1.10	1.80	17.20	363	1.40	1.4	1.24	19.70	487	0.443	209	185	198	168	
95	1.10	1.80	18.70	444	1.40	1.6	1.40	21.90	617	0.320	264	235	243	202	
120	1.20	1.80	20.50	538	1.50	1.6	1.40	23.60	726	0.253	308	276	276	230	
150	1.40	2.00	22.70	666	1.70	1.6	1.40	25.50	850	0.206	350	314	308	256	
185	1.60	2.00	24.90	797	1.90	1.6	1.40	27.70	999	0.164	406	366	349	290	
240	1.70	2.00	27.30	985	2.00	1.6	1.40	30.10	1208	0.125	480	434	404	335	
300	1.80	2.00	30.10	1186	2.10	1.6	1.56	33.20	1452	0.100	551	500	454	376	
400	2.00	2.20	33.80	1511	2.40	2.0	1.56	37.50	1869	0.0778	647	589	518	429	
500	2.20	2.20	37.20	1867	2.60	2.0	1.56	40.90	2261	0.0605	751	685	588	485	
630	2.40	2.20	40.70	2321	2.80	2.0	1.72	44.70	2789	0.0469	868	793	663	546	
800	2.60	2.40	46.40	2938	3.10	2.0	1.88	50.50	3473	0.0367	992	907	740	608	
1000	2.80	2.60	50.70	3638	3.30	2.5	2.04	55.70	4364	0.0291	1117	1022	812	665	

**TABLE 1.2: FINVUL - X 1100 V Grade Two Core, Aluminium Conductor, XLPE Insulated, Unarmoured/Armoured, PVC Type ST-2 Jacketed Cables**

Norn. Cross Sectional Area Sq.mm	Norn. Thickness of XLPE Insulation mm	Unarmoured			Armoured				Max. DC Conductor Resistance at 20°C Ohm/km	A.G. Current Rating	
		Norn. Thickness of Outer Sheath mm	App rox. Overall Dia. mm	Approx. Cable Weight kg/km	Norn. Steel Armour Size mm	Min. Thickness of Outer Sheath mm	Approx. Overall Dia. mm	Approx. Cable Weight kg/km		In Air Amps	In Ground Amps
4	0.70	1.80	11.80	183	1.4 (W)	1.24	14.00	341	7.41	38	42
6	0.70	1.80	12.90	215	1.4 (W)	1.24	15.00	396	4.61	50	55
10	0.70	1.80	17.30	132	1.4 (W)	1.24	18.10	530	3.08	64	68
16	0.70	1.80	19.00	147	1.4 (W)	1.40	20.40	643	1.91	83	89
25	0.90	2.00	19.60	166	4 X 0.8 (F)	1.40	19.30	582	1.20	109	114
35	0.90	2.00	21.20	181	4 X 0.8 (F)	1.40	20.90	680	0.868	133	136
50	1.00	2.00	23.70	204	4 X 0.8 (F)	1.40	23.40	821	0.641	162	161
70	1.10	2.00	27.10	236	4 X 0.8 (F)	1.56	27.10	1054	0.443	204	197
95	1.10	2.20	30.00	286	4 X 0.8 (F)	1.56	29.40	1271	0.320	251	235
120	1.20	2.20	32.70	314	4 X 0.8 (F)	1.56	32.10	1495	0.253	287	266
150	1.40	2.20	34.50	333	4 X 0.8 (F)	1.72	34.30	1769	0.206	328	296
185	1.60	2.40	38.30	401	4 X 0.8 (F)	1.72	37.90	2101	0.164	379	335
240	1.70	2.60	42.20	476	4 X 0.8 (F)	1.88	41.40	2534	0.125	448	385
300	1.80	2.80	46.70	566	4 X 0.8 (F)	2.04	46.30	3079	0.100	513	432
400	2.00	3.00	52.30	678	4 X 0.8 (F)	2.36	51.80	3834	0.0778	593	487

**TABLE 1.3: FINVUL-X 1100 V Grade Three Core, Aluminium Conductor, XLPE Insulated, Unarmoured/Armoured, PVC Type ST-2 Jacketed Cables**

Nom. Cross Sectional Area Sq.mm.	Norn. Thickness of XLPE Insulation mm	Unarmoured			Armoured				Max. DC Conductor Resistance at 20°C Ohm/km	A.G. Current Rating	
		Norn. Thickness of Outer Sheath mm	App rox. Overall Dia. mm	Approx. Cable Weight kg/km	Norn. Steel Armour Size mm	Min. Thickness of Outer Sheath mm	Approx. Overall Dia. mm	Approx. Cable Weight kg/km		In Air Amps	In Ground Amps
4	0.70	1.80	12.40	210	1.4 (W)	1.24	14.60	376	7.41	32	35
6	0.70	1.80	13.60	250	1.4 (W)	1.24	15.70	432	4.61	42	46
10	0.70	1.80	18.20	294	1.4 (W)	1.24	18.90	659	3.08	54	57
16	0.70	1.80	18.40	372	4 X 0.8 (F)	1.24	18.20	540	1.91	69	74
25	0.90	2.00	21.50	528	4 X 0.8 (F)	1.40	21.20	727	1.20	93	95
35	0.90	2.00	23.50	640	4 X 0.8 (F)	1.40	23.20	863	0.868	114	114
50	1.00	2.00	26.70	819	4 X 0.8 (F)	1.40	26.00	1053	0.641	138	134
70	1.10	2.20	31.10	1101	4 X 0.8 (F)	1.56	30.50	1386	0.443	175	164
95	1.10	2.20	33.60	1359	4 X 0.8 (F)	1.56	33.00	1671	0.320	216	197
120	1.20	2.20	36.80	1633	4 X 0.8 (F)	1.56	36.20	1982	0.253	249	223
150	1.40	2.40	39.30	1995	4 X 0.8 (F)	1.72	38.90	2386	0.206	284	249
185	1.60	2.60	43.50	2428	4 X 0.8 (F)	1.88	43.00	2854	0.164	329	282
240	1.70	2.80	48.10	3043	4 X 0.8 (F)	2.04	47.70	3528	0.125	392	327
300	1.80	3.00	53.80	3760	4 X 0.8 (F)	2.20	52.80	4232	0.100	452	369
400	2.00	3.20	59.80	4723	4 X 0.8 (F)	2.52	59.30	5318	0.0778	526	420

**TABLE 1.4: FINVUL - X 1100 V Grade 3.5 Core, Aluminium Conductor, XLPE Insulated, Unarmoured/Armoured, PVC Type ST-2 Jacketed Cables**

Nom. Cross Sectional Area Sq.mm.	Norn. Thickness of XLPE Insulation mm	Unarmoured			Armoured				Max. DC Conductor Resistance at 20°C Ohm/km	A.C. Current Rating	
		Norn. Thickness of Outer Sheath mm	App rox. Overall Dia. mm	Approx. Cable Weight kg/km	Norn. Steel Armour Size mm	Min. Thickness of Outer Sheath mm	Approx. Overall Dia. mm	Approx. Cable Weight kg/km		In Air Amps	In Ground Amps
25	0.90	2.00	23.1	604	4 X 0.8 (F)	1.40	22.8	821	1.20	93	95
35	0.90	2.00	25.2	719	4 X 0.8 (F)	1.40	24.9	961	0.868	114	114
50	1.00	2.00	28.7	940	4 X 0.8 (F)	1.40	28.1	1195	0.641	138	134
70	1.10	2.20	33.6	1258	4 X 0.8 (F)	1.56	33.0	1569	0.443	175	164
95	1.10	2.20	36.4	1560	4 X 0.8 (F)	1.56	35.8	1903	0.320	216	197
120	1.20	2.20	39.2	1896	4 X 0.8 (F)	1.72	39.0	2303	0.253	249	223
150	1.40	2.40	43.3	2284	4 X 0.8 (F)	1.72	42.9	2720	0.206	284	249
185	1.60	2.60	48.0	2800	4 X 0.8 (F)	1.88	47.5	3276	0.164	329	282
240	1.70	2.80	53.1	3506	4 X 0.8 (F)	2.04	52.7	4048	0.125	392	327
300	1.80	3.00	59.3	4343	4 X 0.8 (F)	2.20	58.4	4872	0.100	452	369
400	2.00	3.40	66.4	5492	4 X 0.8 (F)	2.52	65.6	6101	0.0778	526	420
185	1.60	2.60	43.50	2428	4 X 0.8 (F)	1.88	43.00	2854	0.164	329	282
240	1.70	2.80	48.10	3043	4 X 0.8 (F)	2.04	47.70	3528	0.125	392	327
300	1.80	3.00	53.80	3760	4 X 0.8 (F)	2.20	52.80	4232	0.100	452	369
400	2.00	3.20	59.80	4723	4 X 0.8 (F)	2.52	59.30	5318	0.0778	526	420

**TABLE 1.5: FINVUL - X 1100 V Grade 4 Core, Aluminium Conductor, XLPE Insulated, Unarmoured/Armoured, PVC Type ST-2 Jacketed Cables**

Nom. Cross Sectional Area Sq.mm.	Norn. Thickness of XLPE Insulation mm	Unarmoured			Armoured				Max. DC Conductor Resistance at 20°C Ohm/km	A.C. Current Rating	
		Norn. Thickness of Outer Sheath mm	App rox. Overall Dia. mm	Approx. Cable Weight kg/km	Norn. Steel Armour Size mm	Min. Thickness of Outer Sheath mm	Approx. Overall Dia. mm	Approx. Cable Weight kg/km		In Air Amps	In Ground Amps
4	0.70	1.80	13.4	242	1.4(W)	1.24	15.6	414	7.41	32	35
6	0.70	1.80	14.7	291	1.4 (W)	1.24	16.8	479	4.61	42	46
10	0.70	1.80	19.7	367	1.4 (W)	1.40	21.1	713	3.08	54	57
16	0.70	1.80	20.0	449	4 X 0.8 (F)	1.40	20.2	653	1.91	69	74
25	0.90	2.00	24.0	652	4 X 0.8 (F)	1.40	23.7	882	1.20	93	95
35	0.90	2.00	26.2	798	4 X 0.8 (F)	1.40	26.0	1055	0.868	114	114
50	1.00	2.00	29.6	1002	4 X 0.8 (F)	1.56	29.7	1317	0.641	138	134
70	1.10	2.20	35.1	1387	4 X 0.8 (F)	1.56	34.6	1717	0.443	175	164
95	1.10	2.20	38.1	1726	4 X 0.8 (F)	1.56	37.6	2091	0.320	216	197
120	1.20	2.40	42.3	2123	4 X 0.8 (F)	1.72	42.0	2550	0.253	249	223
150	1.40	2.60	45.2	2597	4 X 0.8 (F)	1.88	44.8	3042	0.206	284	249
185	1.60	2.80	50.6	3203	4 X 0.8 (F)	2.04	49.7	3647	0.164	329	282
240	1.70	3.00	55.8	4016	4 X 0.8 (F)	2.20	55.0	4523	0.125	392	327
300	1.80	3.20	62.0	4900	4 X 0.8 (F)	2.36	61.4	5482	0.100	452	369
400	2.00	3.60	69.4	6223	4 X 0.8 (F)	2.68	68.6	6846	0.0778	526	420

**TABLE 1.6: FINVUL - X 1100 V Grade Single Core, Copper Conductor, XLPE Insulated, Unarmoured/Armoured, PVC Type ST-2 Jacketed Cables**

Norn. Cross Sectional Area Sq.mm	Unarmoured				Armoured					Max. DC Conductor Resistance at 20°C Ohm/km	A.G. Current Rating			
	Norn. Thickness of XLPE Insulation mm	Norn. Thickness of Outer Sheath mm	Approx. Overall Dia. mm	Approx. Cable Weight kg/km	Norn. Thickness of XLPE Insulation mm	Norn. Dia of Alu. Wire for Armour mm	Min. Thickness of Outer Sheath mm	Approx. Overall Dia. mm	Approx. Cable Weight kg/km		In Air		In Ground	
											2 Cables Amps	3 Cables Amps	2 Cables Amps	3 Cables Amps
10	0.70	1.80	9.70	168	1.00	1.4	1.24	12.10	238	1.83	83	71	90	77
16	0.70	1.80	10.70	233	1.00	1.4	1.24	13.20	310	1.15	108	94	115	98
25	0.90	1.80	12.30	348	1.20	1.4	1.24	14.80	439	0.727	144	126	148	126
35	0.90	1.80	13.40	445	1.20	1.4	1.24	15.90	543	0.524	176	154	177	150
50	1.00	1.80	15.00	578	1.30	1.4	1.24	17.50	688	0.387	212	187	208	177
70	1.10	1.80	17.20	776	1.40	1.4	1.24	19.70	900	0.268	269	238	255	216
95	1.10	1.80	18.70	1015	1.40	1.6	1.40	21.90	1188	0.193	340	303	312	260
120	1.20	1.80	20.50	1261	1.50	1.6	1.40	23.60	1449	0.153	396	354	355	295
150	1.40	2.00	22.70	1560	1.70	1.6	1.40	25.50	1745	0.124	450	403	396	329
185	1.60	2.00	24.90	1911	1.90	1.6	1.40	27.70	2114	0.0991	519	468	447	371
240	1.70	2.00	27.30	2451	2.00	1.6	1.40	30.10	2674	0.0754	613	553	515	427
300	1.80	2.00	30.10	3032	2.10	1.6	1.56	33.20	3298	0.0601	700	634	576	477
400	2.00	2.20	33.80	3871	2.40	2.0	1.56	37.50	4230	0.0470	813	737	651	537
500	2.20	2.20	37.20	4892	2.60	2.0	1.56	40.90	5286	0.0366	930	844	727	598
630	2.40	2.20	40.70	6207	2.80	2.0	1.72	44.70	6675	0.0283	1056	961	806	661
800	2.60	2.40	46.40	7672	3.10	2.0	1.88	50.50	8207	0.0221	1179	1077	877	721
1000	2.80	2.60	50.70	9763	3.30	2.5	2.04	55.70	10489	0.0176	1288	1188	935	772

**TABLE 1.7: FINVUL - X 1100 V Grade Two Core, Copper Conductor, XLPE Insulated, Unarmoured/Armoured, PVC Type ST-2 Jacketed Cables**

Nom. Cross Sectional Area Sq.mm.	Norn. Thickness of XLPE Insulation mm	Unarmoured			Armoured				Max. DC Conductor Resistance at 20°C Ohm/km	A.C. Current Rating	
		Norn. Thickness of Outer Sheath mm	App rox. Overall Dia. mm	Approx. Cable Weight kg/km	Norn. Steel Armour Size mm	Min. Thickness of Outer Sheath mm	Approx. Overall Dia. mm	Approx. Cable Weight kg/km		In Air Amps	In Ground Amps
4	0.70	1.80	11.80	229	1.4 (W)	1.24	14.00	386	4.61	48	54
6	0.70	1.80	12.90	281	1.4 (W)	1.24	15.00	459	3.08	61	67
10	0.70	1.80	17.30	327	1.4 (W)	1.24	18.10	662	1.83	83	89
16	0.70	1.80	19.00	560	1.4 (W)	1.40	20.40	841	1.15	108	115
25	0.90	2.00	19.60	823	4 X 0.8 (F)	1.40	19.30	904	0.727	140	147
35	0.90	2.00	21.20	1023	4 X 0.8 (F)	1.40	20.90	1120	0.524	172	176
50	1.00	2.00	23.70	1349	4 X 0.8 (F)	1.40	23.40	1419	0.387	208	208
70	1.10	2.00	27.10	1757	4 X 0.8 (F)	1.56	27.10	1874	0.268	262	253
95	1.10	2.20	30.00	2308	4 X 0.8 (F)	1.56	29.40	2413	0.193	322	302
120	1.20	2.20	32.70	2819	4 X 0.8 (F)	1.56	32.10	2933	0.153	368	340
150	1.40	2.20	34.50	3391	4 X 0.8 (F)	1.72	34.30	3525	0.124	419	379
185	1.60	2.40	38.30	4186	4 X 0.8 (F)	1.72	37.90	4303	0.0991	482	425
240	1.70	2.60	42.20	5347	4 X 0.8 (F)	1.88	41.40	5446	0.0754	566	486
300	1.80	2.80	46.70	6693	4 X 0.8 (F)	2.04	46.30	6747	0.0601	644	541
400	2.00	3.00	52.30	8413	4 X 0.8 (F)	2.36	51.80	8510	0.0470	734	602

**TABLE 1.8: FINVUL - X 1100 V Grade Three Core, Copper Conductor, XLPE Insulated, Unarmoured/Armoured, PVC Type ST-2 Jacketed Cables**

Nom. Cross Sectional Area Sq.mm.	Norn. Thickness of XLPE Insulation mm	Unarmoured			Armoured				Max. DC Conductor Resistance at 20°C Ohm/km	A.C. Current Rating	
		Norn. Thickness of Outer Sheath mm	App rox. Overall Dia. mm	Approx. Cable Weight kg/km	Norn. Steel Armour Size mm	Min. Thickness of Outer Sheath mm	Approx. Overall Dia. mm	Approx. Cable Weight kg/km		In Air Amps	In Ground Amps
4	0.70	1.80	12.40	278	1.4(W)	1.24	14.60	444	4.61	41	45
6	0.70	1.80	13.60	348	1.4 (W)	1.24	15.70	528	3.08	52	56
10	0.70	1.80	18.20	480	1.4 (W)	1.24	18.90	845	1.83	70	74
16	0.70	1.80	18.40	669	4 X 0.8 (F)	1.24	18.20	837	1.15	89	95
25	0.90	2.00	21.50	1011	4 X 0.8 (F)	1.40	21.20	1210	0.727	119	122
35	0.90	2.00	23.50	1306	4 X 0.8 (F)	1.40	23.20	1529	0.524	147	146
50	1.00	2.00	26.70	1716	4 X 0.8 (F)	1.40	26.00	1950	0.387	179	173
70	1.10	2.20	31.10	2331	4 X 0.8 (F)	1.56	30.50	2616	0.268	226	212
95	1.10	2.20	33.60	3072	4 X 0.8 (F)	1.56	33.00	3384	0.193	279	254
120	1.20	2.20	36.80	3790	4 X 0.8 (F)	1.56	36.20	4139	0.153	320	287
150	1.40	2.40	39.30	4673	4 X 0.8 (F)	1.72	38.90	5064	0.124	365	321
185	1.60	2.60	43.50	5740	4 X 0.8 (F)	1.88	43.00	6166	0.0991	422	362
240	1.70	2.80	48.10	7405	4 X 0.8 (F)	2.04	47.70	7890	0.0754	500	418
300	1.80	3.00	53.80	9262	4 X 0.8 (F)	2.20	52.80	9734	0.0601	574	469
400	2.00	3.20	59.80	11749	4 X 0.8 (F)	2.52	59.30	12344	0.0470	662	528

**TABLE 1.9: FINVUL - X 1100 V Grade 3.5 Core, Copper Conductor, XLPE Insulated, Unarmoured/Armoured, PVC Type ST-2 Jacketed Cables**

Nom. Cross Sectional Area Sq.mm.	Norn. Thickness of XLPE Insulation mm	Unarmoured			Armoured				Max. DC Conductor Resistance at 20°C Ohm/km	A.C. Current Rating	
		Norn. Thickness of Outer Sheath mm	App rox. Overall Dia. mm	Approx. Cable Weight kg/km	Norn. Steel Armour Size mm	Min. Thickness of Outer Sheath mm	Approx. Overall Dia. mm	Approx. Cable Weight kg/km		In Air Amps	In Ground Amps
4	0.70	1.80	12.40	278	1.4(W)	1.24	14.60	444	4.61	41	45
6	0.70	1.80	13.60	348	1.4 (W)	1.24	15.70	528	3.08	52	56
10	0.70	1.80	18.20	480	1.4 (W)	1.24	18.90	845	1.83	70	74
16	0.70	1.80	18.40	669	4 X 0.8 (F)	1.24	18.20	837	1.15	89	95
25	0.90	2.00	21.50	1011	4 X 0.8 (F)	1.40	21.20	1210	0.727	119	122
35	0.90	2.00	23.50	1306	4 X 0.8 (F)	1.40	23.20	1529	0.524	147	146
50	1.00	2.00	26.70	1716	4 X 0.8 (F)	1.40	26.00	1950	0.387	179	173
70	1.10	2.20	31.10	2331	4 X 0.8 (F)	1.56	30.50	2616	0.268	226	212
95	1.10	2.20	33.60	3072	4 X 0.8 (F)	1.56	33.00	3384	0.193	279	254
120	1.20	2.20	36.80	3790	4 X 0.8 (F)	1.56	36.20	4139	0.153	320	287
150	1.40	2.40	39.30	4673	4 X 0.8 (F)	1.72	38.90	5064	0.124	365	321
185	1.60	2.60	43.50	5740	4 X 0.8 (F)	1.88	43.00	6166	0.0991	422	362
240	1.70	2.80	48.10	7405	4 X 0.8 (F)	2.04	47.70	7890	0.0754	500	418
300	1.80	3.00	53.80	9262	4 X 0.8 (F)	2.20	52.80	9734	0.0601	574	469
400	2.00	3.20	59.80	11749	4 X 0.8 (F)	2.52	59.30	12344	0.0470	662	528

**TABLE 1.10: FINVUL - X 1100 V Grade 4 Core, Copper Conductor, XLPE Insulated, Unarmoured/Armoured, PVC Type ST-2 Jacketed Cables**

Nom. Cross Sectional Area Sq.mm.	Norn. Thickness of XLPE Insulation mm	Unarmoured			Armoured				Max. DC Conductor Resistance at 20°C Ohm/km	A.C. Current Rating	
		Norn. Thickness of Outer Sheath mm	App rox. Overall Dia. mm	Approx. Cable Weight kg/km	Norn. Steel Armour Size mm	Min. Thickness of Outer Sheath mm	Approx. Overall Dia. mm	Approx. Cable Weight kg/km		In Air Amps	In Ground Amps
4	0.70	1.80	13.4	333	1.4 (W)	1.24	15.6	504	4.61	41	45
6	0.70	1.80	14.7	422	1.4 (W)	1.24	16.8	607	3.08	52	56
10	0.70	1.80	19.7	615	1.4 (W)	1.40	21.1	961	1.83	70	74
16	0.70	1.80	20.0	849	4 X 0.8 (F)	1.40	20.2	1053	1.15	89	95
25	0.90	2.00	24.0	1308	4 X 0.8 (F)	1.40	23.7	1538	0.727	119	122
35	0.90	2.00	26.2	1690	4 X 0.8 (F)	1.40	26.0	1947	0.524	147	146
50	1.00	2.00	29.6	2202	4 X 0.8 (F)	1.56	29.7	2517	0.387	179	173
70	1.10	2.20	35.1	3047	4 X 0.8 (F)	1.56	34.6	3377	0.268	226	212
95	1.10	2.20	38.1	4026	4 X 0.8 (F)	1.56	37.6	4391	0.193	279	254
120	1.20	2.40	42.3	5027	4 X 0.8 (F)	1.72	42.0	5454	0.153	320	287
150	1.40	2.60	45.2	6177	4 X 0.8 (F)	1.88	44.8	6622	0.124	365	321
185	1.60	2.80	50.6	7659	4 X 0.8 (F)	2.04	49.7	8103	0.0991	422	362
240	1.70	3.00	55.8	9864	4 X 0.8 (F)	2.20	55.0	10371	0.0754	500	418
300	1.80	3.20	62.0	12288	4 X 0.8 (F)	2.36	61.4	12870	0.0601	574	469
400	2.00	3.60	69.4	15663	4 X 0.8 (F)	2.68	68.6	16286	0.0470	662	528

**TABLE 1.11: FINVUL - X 100 V Grade 1.5 sq mm Solid Copper Conductor, XLPE Insulated, Unarmoured/Armoured, PVC Type ST-2 Jacketed Cables, Multicore Control Cables**

Nom. Cross Sectional Area Sq.mm.	Norn. Thickness of XLPE Insulation mm	Unarmoured			Armoured				Max. DC Conductor Resistance at 20°C Ohm/km	A.C. Current Rating	
		Norn. Thickness of Outer Sheath mm	App rox. Overall Dia. mm	Approx. Cable Weight kg/km	Norn. Steel Armour Size mm	Min. Thickness of Outer Sheath mm	Approx. Overall Dia. mm	Approx. Cable Weight kg/km		In Air Amps	In Ground Amps
2	0.70	1.80	10.9	154	1.4 (W)	1.24	11.9	276	12.1	27	31
3	0.70	1.80	11.4	178	1.4 (W)	1.24	12.4	309	12.1	23	26
4	0.70	1.80	12.2	180	1.4 (W)	1.24	13.1	346	12.1	23	26
5	0.70	1.80	13.0	212	1.4 (W)	1.24	14.0	400	12.1	23	26
6	0.70	1.80	13.9	246	1.4 (W)	1.24	14.9	443	12.1	20	23
7	0.70	1.80	13.9	252	1.4 (W)	1.24	14.9	450	12.1	19	22
9	0.70	1.80	16.8	321	1.4 (W)	1.24	17.8	594	12.1	18	20
10	0.70	1.80	16.8	339	1.4 (W)	1.24	17.8	611	12.1	17	19
12	0.70	1.80	17.3	380	1.4 (W)	1.24	19.1	680	12.1	16	18
14	0.70	1.80	18.2	423	1.4 (W)	1.40	19.8	736	12.1	15	17
16	0.70	1.80	19.0	468	4 X 0.8 (F)	1.40	19.5	692	12.1	15	17
19	0.70	1.80	19.9	538	4 X 0.8 (F)	1.40	20.4	760	12.1	14	16
24	0.70	2.00	23.3	684	4 X 0.8 (F)	1.40	23.4	903	12.1	13	14
27	0.70	2.00	23.7	743	4 X 0.8 (F)	1.40	23.8	985	12.1	11	14
30	0.70	2.00	24.5	807	4 X 0.8 (F)	1.40	24.6	1046	12.1	11	12
37	0.70	2.00	26.2	954	4 X 0.8 (F)	1.40	26.3	1213	12.1	10	11
44	0.70	2.00	29.2	1117	4 X 0.8 (F)	1.40	29.3	1416	12.1	9	11
52	0.70	2.00	30.4	1275	4 x 0.8 (F)	1.56	30.8	1618	12.1	9	10
61	0.70	2.20	32.8	1506	4 X 0.8 (F)	1.56	32.9	1853	12.1	8	9

**TABLE 1.12: FINVUL - X 1100 V Grade 2.5 sq mm Solid Copper Conductor, XLPE Insulated, Unarmoured/Armoured, PVC Type ST-2 Jacketed Cables, Multicore Control Cables**

Nom. Cross Sectional Area Sq.mm.	Norn. Thickness of XLPE Insulation mm	Unarmoured			Armoured				Max. DC Conductor Resistance at 20°C Ohm/km	A.C. Current Rating	
		Norn. Thickness of Outer Sheath mm	App rox. Overall Dia. mm	Approx. Cable Weight kg/km	Norn. Steel Armour Size mm	Min. Thickness of Outer Sheath mm	Approx. Overall Dia. mm	Approx. Cable Weight kg/km		In Air Amps	In Ground Amps
2	0.70	1.80	11.7	183	1.4 (W)	1.24	12.7	299	7.41	36	41
3	0.70	1.80	12.2	216	1.4 (W)	1.24	13.2	342	7.41	30	34
4	0.70	1.80	13.1	226	1.4 (W)	1.24	14.1	401	7.41	30	34
5	0.70	1.80	14.1	269	1.4 (W)	1.24	15.0	453	7.41	30	34
6	0.70	1.80	15.1	313	1.4 (W)	1.24	16.0	506	7.41	26	29
7	0.70	1.80	15.1	328	1.4 (W)	1.24	16.0	522	7.41	25	27
9	0.70	1.80	18.4	420	1.4 (W)	1.40	20.2	776	7.41	22	25
10	0.70	1.80	18.4	446	4 X 0.8 (F)	1.24	19.0	633	7.41	21	24
12	0.70	1.80	18.9	505	4 X 0.8 (F)	1.40	19.5	705	7.41	20	22
14	0.70	1.80	19.9	568	4 X 0.8 (F)	1.40	20.4	790	7.41	19	21
16	0.70	2.00	21.3	653	4 X 0.8 (F)	1.40	21.4	853	7.41	18	20
19	0.70	2.00	22.3	755	4 X 0.8 (F)	1.40	22.4	976	7.41	17	19
24	0.70	2.00	25.6	932	4 X 0.8 (F)	1.40	25.7	1192	7.41	16	17
27	0.70	2.00	26.1	1019	4 X 0.8 (F)	1.40	26.2	1278	7.41	16	16
30	0.70	2.00	27.0	1111	4 X 0.8 (F)	1.40	27.1	1368	7.41	14	16
37	0.70	2.00	29.0	1325	4 X 0.8 (F)	1.40	29.1	1625	7.41	13	15
44	0.70	2.20	33.0	1604	4 X 0.8 (F)	1.56	33.1	1950	7.41	12	14
52	0.70	2.20	34.4	1839	4 X 0.8 (F)	1.56	34.5	2206	7.41	12	13
61	0.70	2.20	36.4	2110	4 X 0.8 (F)	1.56	36.5	2496	7.41	11	12

## 2.0 TECHNICAL DATA FOR HT CABLES

Table 2.1

Continuous current rating of Finopower XLPE Cables  
for Voltage grade 1.9/3.3 kV to 3.8/6.6 kV with Aluminium/Copper conductor

Cross-sectional area  Sqmm	Single Core Armoured				Three Core Armoured			
	Aluminium conductor		Copper conductor		Aluminium conductor		Copper conductor	
	In ground	In Air	In ground	In Air	In ground	In Air	In ground	In Air
	Amps	Amps	Amps	Amps	Amps	Amps	Amps	Amps
25	99	115	127	148	94	102	121	132
35	117	139	151	179	112	123	144	159
50	138	166	178	214	131	146	169	188
70	168	208	216	267	160	182	206	234
95	200	252	256	323	191	221	246	284
120	227	292	290	374	216	254	278	326
150	252	329	323	422	241	286	310	368
185	285	380	362	484	273	330	350	422
240	326	448	411	565	315	385	401	492
300	365	511	456	641	354	440	449	559
400	412	593	508	734	403	512	506	642
500	461	680	559	828	457	590	565	730
630	514	777	611	929				
800	552	863	638	1002				
1000	595	954	672	1083				

**Table 2.2**  
**Continuous current rating of Finopower XLPE Cables**  
**for Voltage grade 6.6/6.6 kV to 11/11 kV with Aluminium/ Copper conductor**

Cross-sectional area  Sqmm	Single Core Armoured				Three Core Armoured			
	Aluminium conductor		Copper conductor		Aluminium conductor		Copper conductor	
	In ground Amps	In Air Amps	In ground Amps	In Air Amps	In ground Amps	In Air Amps	In ground Amps	In Air Amps
25	99	116	127	150	94	103	121	133
35	118	140	151	181	112	124	144	160
50	138	167	178	216	131	148	169	191
70	168	209	216	269	161	184	207	237
95	200	254	257	326	190	222	245	286
120	227	294	290	376	216	256	278	329
150	252	331	323	424	242	288	311	371
185	284	383	360	487	273	330	349	422
240	326	450	411	568	315	387	401	493
300	365	512	456	643	354	441	449	560
400	412	594	508	735	404	512	506	643
500	461	680	559	828	457	590	565	731
630	514	778	611	930				
800	553	863	639	1003				
1000	595	954	672	1083				

**Table 2.3**  
**Continuous current rating of Finopower XLPE Cables**  
**for Voltage grade 12.7/22 kV to 19/33 kV with Aluminium/Copper conductor**

Cross-sectional area  Sqmm	Single Core Armoured				Three Core Armoured			
	Aluminium conductor		Copper conductor		Aluminium conductor		Copper conductor	
	In ground Amps	In Air Amps	In ground Amps	In Air Amps	In ground Amps	In Air Amps	In ground Amps	In Air Amps
35	116	144	150	185	111	127	143	164
50	137	174	176	224	130	152	167	196
70	167	217	214	278	159	189	204	243
95	198	262	253	336	189	227	243	293
120	224	302	285	386	215	262	276	336
150	249	339	317	434	239	294	307	378
185	280	389	355	494	270	336	346	431
240	321	455	404	575	312	393	398	503
300	355	515	442	644	351	448	446	571
400	400	594	490	734	400	519	503	655
500	447	678	538	825	454	598	563	745
630	496	770	586	920				
800	543	866	629	1014				
1000	572	944	643	1074				
1000	595	954	672	1083				

**Table 2.4**  
**Approx. reactance per phase at 50 Hz (ohms/km)**

Cross-sectional area	6.6 kV (E)			6.6 kV (UE) & 11 kV (E)			11 kV (UE)			22 kV (E)			33 kV (E)		
	Single Core Cables		Three Core	Single Core Cables		Three Core	Single Core Cables		Three Core	Single Core Cables		Three Core	Single Core Cables		Three Core
	Armoured	Unarmoured	Armoured	Armoured	Unarmoured	Armoured	Armoured	Unarmoured	Unarmoured	Armoured	Unarmoured	Armoured	Armoured	Unarmoured	Armoured
25	0.140	0.128	0.117	0.143	0.135	0.124	0.151	0.146	0.135						
35	0.134	0.123	0.112	0.137	0.127	0.118	0.143	0.139	0.130	0.149	0.141	0.133			
50	0.127	0.114	0.107	0.131	0.120	0.113	0.141	0.129	0.126	0.140	0.132	0.129	0.151	0.144	0.140
70	0.116	0.110	0.100	0.120	0.114	0.106	0.130	0.123	0.116	0.132	0.125	0.120	0.143	0.137	0.132
95	0.109	0.104	0.094	0.114	0.108	0.099	0.124	0.116	0.111	0.127	0.119	0.112	0.135	0.130	0.125
120	0.107	0.100	0.092	0.111	0.104	0.097	0.121	0.113	0.108	0.121	0.115	0.109	0.129	0.125	0.121
150	0.104	0.097	0.089	0.107	0.101	0.093	0.117	0.109	0.102	0.117	0.112	0.106	0.125	0.121	0.116
185	0.103	0.094	0.086	0.106	0.098	0.090	0.112	0.106	0.099	0.115	0.108	0.101	0.122	0.118	0.112
240	0.099	0.092	0.084	0.102	0.095	0.088	0.108	0.102	0.096	0.109	0.103	0.098	0.118	0.113	0.108
300	0.097	0.090	0.083	0.098	0.092	0.085	0.105	0.098	0.093	0.106	0.100	0.095	0.115	0.110	0.104
400	0.094	0.088	0.081	0.095	0.089	0.083	0.101	0.096	0.090	0.101	0.097	0.091	0.110	0.105	0.100
500	0.093	0.086		0.093	0.087		0.100	0.092		0.099	0.094		0.107	0.102	
630	0.089	0.084		0.090	0.084		0.096	0.090		0.097	0.092		0.103	0.098	
800	0.088	0.082		0.089	0.082		0.093	0.088		0.094	0.089		0.100	0.095	
1000	0.087	0.081		0.087	0.081		0.091	0.085		0.091	0.087		0.098	0.093	

**Table 2.5**  
**Approx. Capacitance for Single and multicore cables (microfarads/km)**

Cross-sectional area	6.6 kV (E)		6.6 kV (UE) & 11 kV (E)		11 kV (UE)		22 kV (E)		33 kV (E)	
	Single Core Cables	Three Core	Single Core Cables	Three Core	Single Core Cables	Three Core	Single Core Cables	Three Core	Single Core Cables	Three Core
25	0.21	0.22	0.18	0.18	0.14	0.14				
35	0.24	0.25	0.20	0.20	0.15	0.15	0.14	0.14		
50	0.27	0.27	0.22	0.22	0.16	0.16	0.15	0.16	0.12	0.12
70	0.31	0.31	0.25	0.25	0.18	0.19	0.17	0.17	0.13	0.13
95	0.36	0.36	0.29	0.29	0.21	0.21	0.19	0.19	0.15	0.15
120	0.39	0.39	0.31	0.31	0.22	0.22	0.21	0.21	0.16	0.16
150	0.43	0.43	0.34	0.34	0.24	0.24	0.23	0.23	0.17	0.17
185	0.47	0.46	0.37	0.37	0.26	0.26	0.24	0.24	0.18	0.18
240	0.52	0.51	0.41	0.41	0.29	0.29	0.27	0.27	0.20	0.20
300	0.53	0.52	0.45	0.45	0.31	0.31	0.29	0.29	0.22	0.22
400	0.55	0.54	0.51	0.51	0.35	0.35	0.32	0.32	0.24	0.24
500	0.56		0.54		0.38		0.35		0.25	
630	0.64		0.63		0.43		0.40		0.29	
800	0.71		0.70		0.48		0.44		0.32	
1000	0.78		0.78		0.52		0.48		0.35	

## Dimension, Weight & Packing data

### Table 2.6: SINGLE CORE CABLES

	3.8/6.6 kV (E) Grade, Unarmoured Cables, A2XCY					6.35/11 kV (E) or 6.6 /6.6 kV (UE) Grade, Unarmoured Cables, A2XCY				
Cross-sectional area	Approx. Dia over insulation	Nom. thickness of outer sheath	Approx. Overall Diameter	Approx. Net weight of cable	Standard Packing Length	Approx. Dia over insulation	Norn. thickness of outer sheath	Approx. Overall Diameter	Approx. Net weight of cable	Standard Packing Length
sqmm	mm	mm	mm	Kg/Km	Mir	mm	mm	mm	Kg/Km	Mir
25	13.0	1.8	18.5	370	1000	14.5	2.0	20.5	440	1000
35	14.0	2.0	20.0	430	1000	15.5	2.0	21.5	490	1000
50	15.5	2.0	21.5	510	1000	17.0	2.0	23.0	560	1000
70	17.0	2.0	23.0	600	500	18.5	2.0	24.5	660	500
95	19.0	2.0	24.5	710	500	20.5	2.0	26.5	780	500
120	20.5	2.0	26.0	820	500	22.0	2.0	27.5	885	500
150	22.0	2.0	27.5	930	500	23.5	2.0	29.0	1000	500
185	23.5	2.0	29.5	1070	500	25.0	2.2	31.0	1170	500
240	25.5	2.2	31.5	1300	500	27.0	2.2	33.0	1370	500
300	28.0	2.2	33.5	1530	500	29.5	2.2	35.0	1590	500
400	32.0	2.2	37.5	1890	500	32.5	2.2	38.0	1920	500
500	35.0	2.4	41.5	2340	500	35.0	2.4	42.0	2340	500
630	39.0	2.4	45.0	2800	500	39.5	2.4	45.5	2820	500
800	42.0	2.6	49.5	3460	500	42.0	2.6	49.5	3470	500
1000	49.0	2.8	54.0	4200	500	49.0	2.8	54.0	4200	500

**Table 2.7: SINGLE CORE CABLES**

	11 /11 kV (UE) Grade, Unarmoured Cables, A2XCY					12.7/22 kV (E) Grade, Unarmoured Cables, A2XCY				
Cross-sectional area	Approx. Dia over insulation	Nom. thickness of outer sheath	Approx. Overall Diameter	Approx. Net weight of cable	Standard Packing Length	Approx. Dia over insulation	Norn. thickness of outer sheath	Approx. Overall Diameter	Approx. Net weight of cable	Standard Packing Length
sqmm	mm	mm	mm	Kg/Km	Mir	mm	mm	mm	Kg/Km	Mir
25	18.5	2.0	24.5	580	1000	---	---	---	---	---
35	19.5	2.0	25.5	640	1000	20.5	2.0	26.5	670	1000
50	21.0	2.0	26.5	720	1000	22.0	2.0	28.0	760	1000
70	22.5	2.0	28.5	830	500	23.5	2.0	29.5	870	500
95	24.0	2.0	30.0	950	500	25.5	2.2	31.5	1030	500
120	26.0	2.2	32.0	1100	500	27.0	2.2	33.0	1150	500
150	27.5	2.2	33.5	1230	500	28.5	2.2	34.5	1280	500
185	29.0	2.2	35.0	1380	500	30.0	2.2	36.0	1440	500
240	31.0	2.2	36.5	1600	500	32.0	2.2	38.0	1650	500
300	33.0	2.2	39.0	1820	500	34.0	2.2	39.7	1880	500
400	36.5	2.4	42.0	2200	500	37.5	2.4	43.0	2270	500
500	39.5	2.4	46.0	2620	500	40.5	2.6	47.0	2730	500
630	43.5	2.6	49.5	3150	500	44.5	2.6	51.0	3250	500
800	46.0	2.8	53.5	3840	500	47.0	2.8	54.5	3930	500
1000	53.0	2.8	57.5	4520	500	53.0	3.0	59.0	4680	500

**Table 2.8: Single Core Cables**

	19/33 kV (E) grade Unarmoured cables A2XCY					3.8/6.6 kV (E) Grade Armoured cables, A2XWaY					
Cross-sectional area	Approx. Dia over insulation	Nom. thickness of outer sheath	Approx. Overall Diameter	Approx. Net weight of cable	Standard Packing Length	Approx. Dia over insulation	Norn. thickness of outer sheath	Min. thickness of outer sheath	Approx. Overall Diameter	Approx. Net weight of cable	Standard Packing Length
sqmm	mm	mm	mm	Kg/Km	Mtr	mm	mm	mm	mm	Kg/Km	Mtr
25						13.0	1.6	1.4	1.4	---	---
35						14.0	1.6	1.4	1.4	670	1000
50	27.5	2.2	33.5	1080	1000	15.5	1.6	1.4	1.4	760	1000
70	29.0	2.2	35.5	1210	500	17.0	1.6	1.4	1.4	870	500
95	31.0	2.2	37.0	1360	500	19.0	1.6	1.4	1.4	1030	500
120	32.5	2.2	38.5	1480	500	20.5	1.6	1.4	1.4	1150	500
150	34.0	2.2	40.0	1630	500	22.0	1.6	1.56	1.56	1280	500
185	35.5	2.4	42.0	1850	500	23.5	1.6	1.56	1.56	1440	500
240	37.5	2.4	44.0	2070	500	25.5	2.0	1.56	1.56	1650	500
300	39.5	2.6	46.3	2375	500	28.0	2.0	1.56	1.56	1880	500
400	43.0	2.6	49.2	2750	500	32.0	2.0	1.72	1.72	2270	500
500	45.5	2.8	53.2	3250	500	35.0	2.0	1.88	1.88	2730	500
630	50.0	2.8	56.5	3800	500	39.0	2.0	1.88	1.88	3250	500
800	52.5	3.0	60.5	4520	500	42.0	2.5	2.04	2.04	3930	500
1000	59.5	3.0	65.0	5320	500	49.0	2.5	2.2	2.2	4680	500

**Table 2.9: Single core Cables.**

	6.35/11 kV (E) or 6.6/6.6 kV (UE) grade Armoured Cables A2XWaY						11/11kV (UE) Grade Armoured Cables, A2XWaY					
Cross-sectional area	Approx. Dia over insulation	Nom. Dia. Of armour wire	Min. thickness of outer sheath	Approx. Overall Diameter	Approx. Net weight of cable	Standard Packing Length	Approx. Dia over insulation	Norn. thickness of outer sheath	Min. thickness of outer sheath	Approx. Overall Diameter	Approx. Net weight of cable	Standard Packing Length
sqmm	mm	mm	mm	mm	Kg/Km	Mtr	mm	mm	mm	mm	Kg/Km	Mtr
25	14.5	1.6	1.4	22.5	550	1000	18.5	1.6	1.4	26.5	720	500
35	15.5	1.6	1.4	23.5	610	1000	19.5	1.6	1.4	27.5	780	500
50	17.0	1.6	1.4	25.0	675	1000	21.0	1.6	1.56	29.0	885	500
70	18.5	1.6	1.4	26.5	790	500	22.5	1.6	1.56	30.5	1010	500
95	20.5	1.6	1.4	28.0	905	500	24.0	1.6	1.56	33.0	1210	500
120	22.0	1.6	1.56	30.0	1040	500	26.0	2.0	1.56	34.5	1325	500
150	23.5	1.6	1.56	31.5	1160	500	27.5	2.0	1.56	36.0	1455	500
185	25.0	2.0	1.56	34.0	1400	500	29.0	2.0	1.56	37.5	1635	500
240	27.0	2.0	1.56	35.5	1610	500	31.0	2.0	1.72	39.5	1890	500
300	29.5	2.0	1.56	37.5	1835	500	33.0	2.0	1.72	41.5	2135	500
400	32.5	2.0	1.72	41.2	2210	500	36.5	2.0	1.88	45.0	2530	500
500	35.0	2.0	1.72	44.5	2650	500	39.5	2.0	1.88	48.5	2990	500
630	39.5	2.0	1.88	48.0	3180	500	43.5	2.5	2.04	53.5	3690	500
800	42.0	2.5	2.04	53.5	3945	500	46.0	2.5	2.2	57.5	4360	500
1000	49.0	2.5	2.2	58.0	4690	500	53.0	2.5	2.2	61.5	5060	500

Table 2.10: Single Core Cables

	12.7/ 22kV (E) Armoured Cable. Type A2XWaY						19/33 kV (E) Armoured Cables, A2XWaY					
Cross-sectional area	Approx. Dia over insulation	Nom. Dia. Of armour wire	Min. thickness of outer sheath	Approx. Overall Diameter	Approx. Net weight of cable	Standard Packing Length	Approx. Dia over insulation	Norn. thickness of outer sheath	Min. thickness of outer sheath	Approx. Overall Diameter	Approx. Net weight of cable	Standard Packing Length
sqmm	mm	mm	mm	mm	Kg/Km	Mtr	mm	mm	mm	mm	Kg/Km	Mtr
35	20.5	1.6	1.40	28.5	830	500						
50	22.0	1.6	1.56	30.0	940	500	27.5	2.0	1.56	36.5	1345	500
70	23.5	1.6	1.56	31.5	1060	500	29.0	2.0	1.56	38.0	1485	500
95	25.5	2.0	1.56	34.0	1270	500	31.0	2.0	1.72	40.0	1670	500
120	27.0	2.0	1.56	35.6	1395	500	32.5	2.0	1.72	41.5	1801	500
150	28.5	2.0	1.56	37.0	1520	500	34.0	2.0	1.72	42.5	1950	500
185	30.0	2.0	1.56	39.0	1735	500	35.5	2.0	1.72	45.0	2185	500
240	32.0	2.0	1.72	40.5	1960	500	37.5	2.0	1.88	46.5	2425	500
300	34.0	2.0	1.72	42.5	2210	500	39.5	2.5	2.04	50.0	2860	500
400	37.5	2.0	1.88	46.0	2600	500	43.0	2.5	2.04	53.0	3265	500
500	40.5	2.5	2.04	50.5	3260	500	45.5	2.5	2.20	57.0	3825	500
630	44.5	2.5	2.04	54.5	3790	500	49.5	2.5	2.20	61.0	4455	500
800	47.0	2.5	2.20	58.5	4465	500	52.5	2.5	2.36	64.5	5100	500
1000	54.0	2.5	2.36	62.5	5250	500	59.5	3.15	2.52	70.0	6185	400

**Table 2.11**  
**Three Core Armoured Cables with Aluminium conductors (A2XCEFY):**

	3.8 / 6.6 kV (E)						6.35/11 kV (E) or 6.6 /6.6 kV (UE)					
Cross-sectional area	Approx. Dia over insulation	Min. thickness of inner sheath	Min. thickness of outer sheath	Approx. Overall Diameter	Approx. Net weight of cable	Standard Packing Length	Approx. Dia over insulation	Norn. thickness of outer sheath	Min. thickness of outer sheath	Approx. Overall Diameter	Approx. Net weight of cable	Standard Packing Length
sqmm	mm	mm	mm	mm	Kg/Km	Mir	mm	mm	mm	mm	Kg/Km	Mir
25	13.0	0.4	1.56	36.5	1680	500	14.5	0.4	1.72	40.5	1970	500
35	14.0	0.4	1.72	39.5	1910	500	15.5	0.5	1.72	43.0	2180	500
50	15.5	0.5	1.72	42.0	2200	500	17.0	0.5	1.88	46.0	2500	500
70	17.0	0.5	1.88	46.0	2610	500	18.5	0.5	1.88	49.5	2890	500
95	19.0	0.5	1.88	49.5	3060	500	20.5	0.6	2.04	54.0	3430	500
120	20.5	0.6	2.04	53.5	3530	500	22.0	0.6	2.20	57.0	3890	500
150	22.0	0.6	2.20	57.0	4020	500	23.5	0.6	2.20	60.5	4350	500
185	23.5	0.6	2.20	60.5	4620	500	25.0	0.7	2.36	64.5	5040	500
240	25.5	0.7	2.36	65.0	5530	500	27.0	0.7	2.52	69.0	5880	500
300	28.0	0.7	2.52	70.5	6460	400	29.5	0.7	2.68	73.5	6720	350
400	32.0	0.7	2.84	79.0	8040	300	32.5	0.7	2.84	80.5	8040	300

**Table 2.12 : Three Core Armoured Cables with Aluminium conductors (A2XCEFY):**

	11/11kV (UE) Grade						19/33 kV (E) Armoured Cables, A2XWaY					
Cross-sectional area	Approx. Dia over insulation	Min. thickness of inner sheath	Min. thickness of outer sheath	Approx. Overall Diameter	Approx. Net weight of cable	Standard Packing Length	Approx. Dia over insulation	Norn. thickness of outer sheath	Min. thickness of outer sheath	Approx. Overall Diameter	Approx. Net weight of cable	Standard Packing Length
sqmm	mm	mm	mm	mm	Kg/Km	mtr	mm	mm	mm	mm	Kg/Km	mtr
25	18.5	0.5	1.88	49.0	2710	500						
35	19.5	0.5	2.04	52.0	2990	500	20.5	0.6	2.04	54.5	3190	500
50	21.0	0.6	2.20	55.5	3370	500	22.0	0.6	2.20	57.5	3580	500
70	22.5	0.6	2.20	59.0	3810	500	23.5	0.6	2.36	61.5	4080	500
95	24.0	0.6	2.36	62.5	4380	500	25.5	0.7	2.36	65.0	4670	500
120	26.0	0.7	2.36	66.0	4870	500	27.0	0.7	2.52	68.5	5170	500
150	27.5	0.7	2.52	69.5	5430	500	28.5	0.7	2.68	72.0	5745	400
185	29.0	0.7	2.68	73.5	6150	400	30.0	0.7	2.68	75.5	6440	350
240	31.0	0.7	2.84	78.0	7050	350	32.0	0.7	2.84	80.0	7330	300
300	33.0	0.7	3.00	82.5	7940	250	34.0	0.7	3.00	84.5	8260	250
400	36.5	0.7	3.00	89.0	9300	200	37.5	0.7	3.00	91.0	9620	200

**Table 2.13: 19/33 kV (E) grade three core Armoured Cables with Aluminium conductors (A2XCEFV):**

Cross-sectional area	Approx. Dia over insulation	Min. thickness of inner sheath	Min. thickness of outer sheath	Approx. Overall Diameter	Approx. Net weight of cable	Standard Packing Length
sqmm	mm	mm	mm	mm	Kg/Km	mtr
50	27.5	0.7	2.52	70.5	5090	500
70	29.0	0.7	2.68	74.5	5670	500
95	31.0	0.7	2.84	78.5	6340	500
120	32.5	0.7	2.84	81.5	6870	500
150	34.0	0.7	3.00	85.0	7510	500
185	35.5	0.7	3.00	88.5	8250	500
240	37.5	0.7	3.00	92.5	9170	500
300	39.5	0.7	3.00	97.0	10060	500
400	43.0	0.7	3.00	103.0	11530	500

Note: a) Nominal Thickness of Insulation for all the cables are as per Table 1  
 b) Tolerance on standard packing length: +/- 5%

**Table 2.14****Conductor and Insulation Data**

**Conductor diameter and Nominal thickness of insulation for different cross-sectional area and different voltage grades with AC/DC Conductor resistance values**

Cross-sectional area	Nominal thickness of insulation					Approx. Conductor diameter	Max. DC resistance at 20°C (Aluminium)	Approx. AC resistance at 90°C (Aluminium)	Max. DC resistance at 20° C (Copper)	Approx. AC resistance at 90° C (copper)
	3.8/6.6 kV	6.6/6.6 & 6.35/11 kV	11/11 kV	12.7/22 kV	19/33 kV					
sqmm	mm	mm	mm	mm	Kg/Km	mm	mm	mm	mm	
25	2.8	3.6	5.5			6.0	1.20	1.54	0.727	0.931
35	2.8	3.6	5.5	6.0		7.0	0.868	1.11	0.524	0.671
50	2.8	3.6	5.5	6.0	8.8	8.5	0.641	0.822	0.387	0.495
70	2.8	3.6	5.5	6.0	8.8	10.0	0.443	0.568	0.268	0.343
95	2.8	3.6	5.5	6.0	8.8	12.0	0.320	0.410	0.193	0.247
120	2.8	3.6	5.5	6.0	8.8	13.1	0.253	0.324	0.153	0.197
150	2.8	3.6	5.5	6.0	8.8	14.6	0.206	0.266	0.124	0.160
185	2.8	3.6	5.5	6.0	8.8	16.5	0.164	0.211	0.0991	0.127
240	2.8	3.6	5.5	6.0	8.8	18.5	0.125	0.161	0.0754	0.0973
300	3.0	3.6	5.5	6.0	8.8	20.5	0.100	0.129	0.0601	0.0774
400	3.3	3.6	5.5	6.0	8.8	23.5	0.0778	0.101	0.0470	0.0606
500	3.5	3.6	5.5	6.0	8.8	26.8	0.0605	0.0782	0.0366	0.0473
630	3.5	3.6	5.5	6.0	8.8	30.5	0.0469	0.0606	0.0283	0.0365
800	3.5	3.6	5.5	6.0	8.8	34.0	0.0367	0.0474	0.0221	0.0285
1000	3.6	3.6	5.5	6.0	8.8	38.0	0.0291	0.0376	0.0176	0.0227

### 3.0 SHORT CIRCUIT RATING

The conductor size in a cable for any type of insulation is governed by its ability to carry short circuit current of the system. The short circuit ratings are based on the assumption that the duration of short circuit is very small, and apparently there is no heat transmitted or produced during short circuit, through the insulation the heat produced if any, the entire amount is absorbed by the conductor.

The short circuit current ratings (r.m.s. values) of XLPE insulated cables are calculated as given below:

Formula for calculating the short circuit rating for other durations:

$$I_t = \frac{I_1}{\sqrt{t}}$$

Where:  $I_1$  = Short circuit current for 1 sec

$I_t$  = Short circuit current for  $t$  sec

$t$  = Duration in seconds

Nominal area of cross section sqmm	Aluminium kA for 1 Sec	Copper mm
1.5	0.14	0.21
2.5	0.24	0.36
4	0.38	0.57
6	0.57	0.86
10	0.9	1.4
16	1.5	2.3
25	2.4	3.6
35	3.3	5.0
50	4.7	7.1
70	6.6	10.0
95	9	13.6
120	11.3	17.1
150	14.2	21.4
185	17.5	26.4
240	22.6	34.3
300	28.3	42.9
400	37.7	57.2
500	47.2	71.5
630	59.4	90.0
800	75.5	114.3
1000	94.4	142.9

## 4.0 RATING FACTORS:

**Table 4.1 Rating factors for ambient air temperature variation**

Ambient Temperature (°C)	25	30	35	40	45	50	55	60
Factor	1.14	1.10	1.05	1.0	0.95	0.89	0.84	0.77

**Table 4.2 Rating factors for ambient ground temperature variation**

Ground Temperature (°C)	15	20	25	30	35	40	45	50
Factor	1.12	1.08	1.04	1.00	0.96	0.91	0.87	0.82

**Table 4.3: Rating factors for various depths of laying (for cables laid directly in ground)**

### LT cables:

Depth of laying cm	Up to 25 mm <sup>2</sup>		Above 25 mm <sup>2</sup> up to 300 sqmm		Above 300 mm <sup>2</sup>	
	Single	Multi	Single	Multi	Single	Multi
75	1	1	1	1	1	1
90	0.98	0.98	0.98	0.98	0.98	0.98
105	0.97	0.98	0.96	0.97	0.96	0.96
120	0.96	0.97	0.95	0.95	0.94	0.95
150	0.94	0.95	0.93	0.93	0.92	0.93
180	0.93	0.93	0.91	0.92	0.9	0.91
200	0.92	0.93	0.9	0.91	0.89	0.9
250	0.9	0.92	0.89	0.89	0.87	0.88
300	0.9	0.9	0.87	0.88	0.86	0.87

### HT Cables:

Depth of laying cm	3.3, 6.6, & 11kV			22 & 33 kV		
	Single core		Three core	Single core		Three core
	<.185 mm <sup>2</sup>	> 185 mm <sup>2</sup>		<.185 mm <sup>2</sup>	> 185 mm <sup>2</sup>	
90	1.00	1.00	1.00			
105	0.98	0.98	0.99	1.00	1.00	1.00
120	0.97	0.97	0.98	0.99	0.98	0.99
150	0.95	0.94	0.96	0.96	0.96	0.97
180	0.93	0.92	0.95	0.95	0.94	0.96
200	0.92	0.91	0.94	0.94	0.93	0.95
250	0.90	0.89	0.93	0.92	0.90	0.94
300	0.89	0.88	0.91	0.91	0.89	0.92

**Table 4.4: Rating factors for variations in soil thermal resistivities for single-core 3.3 kV, 6.6 kV and 11 kV cables laid direct in ground**

Nominal area of conductor mm <sup>2</sup>	Values of soil thermal resistivity K.m/W					
	1.0	1.2	1.5	2.0	2.5	3.0
25	1.17	1.09	1.00	0.89	0.80	0.74
35	1.18	1.10	1.00	0.89	0.80	0.74
50	1.18	1.10	1.00	0.88	0.80	0.74
70	1.19	1.10	1.00	0.88	0.80	0.73
95	1.19	1.10	1.00	0.88	0.79	0.73
120	1.19	1.10	1.00	0.88	0.79	0.73
150	1.19	1.10	1.00	0.88	0.79	0.73
185	1.19	1.11	1.00	0.88	0.79	0.73
240	1.19	1.11	1.00	0.88	0.79	0.73
300	1.20	1.11	1.00	0.88	0.79	0.72
400	1.20	1.11	1.00	0.87	0.79	0.72
500	1.20	1.11	1.00	0.87	0.79	0.72
630	1.20	1.11	1.00	0.87	0.79	0.72
800	1.20	1.11	1.00	0.87	0.78	0.72
1000	1.21	1.11	1.00	0.87	0.78	0.72

**Table 4.5: Rating factors for variations in soil thermal resistivities for single-core 22 kV and 33 kV cables laid direct in ground**

Nominal area of conductor mm <sup>2</sup>	Values of soil thermal resistivity K.m/W					
	1.0	1.2	1.5	2.0	2.5	3.0
35	1.17	1.09	1.00	0.89	0.81	0.74
50	1.17	1.09	1.00	0.89	0.81	0.74
70	1.17	1.09	1.00	0.89	0.80	0.74
95	1.17	1.09	1.00	0.89	0.80	0.74
120	1.18	1.10	1.00	0.89	0.80	0.74
150	1.18	1.10	1.00	0.88	0.80	0.74
185	1.18	1.10	1.00	0.88	0.80	0.74
240	1.18	1.10	1.00	0.88	0.80	0.73
300	1.19	1.10	1.00	0.88	0.79	0.73
400	1.19	1.10	1.00	0.88	0.79	0.73
500	1.19	1.10	1.00	0.88	0.79	0.73
630	1.19	1.10	1.00	0.88	0.79	0.73
800	1.20	1.10	1.00	0.88	0.79	0.72
800	1.20	1.11	1.00	0.87	0.78	0.72
1000	1.21	1.11	1.00	0.87	0.78	0.72

**Table 4.6: Rating factors for variations in soil thermal resistivities for three-core 3.3 kV, 6.6 kV and 11 kV cables laid direct in ground**

Nominal area of conductor mm <sup>2</sup>	Values of soil thermal resistivity K.m/W					
	1.0	1.2	1.5	2.0	2.5	3.0
25	1.15	1.08	1.00	0.90	0.82	0.76
35	1.15	1.08	1.00	0.90	0.82	0.76
50	1.15	1.08	1.00	0.90	0.82	0.76
70	1.15	1.08	1.00	0.89	0.82	0.76
95	1.15	1.09	1.00	0.89	0.82	0.76
120	1.15	1.09	1.00	0.89	0.82	0.76
150	1.15	1.09	1.00	0.89	0.81	0.75
185	1.16	1.09	1.00	0.89	0.81	0.75
240	1.16	1.09	1.00	0.89	0.81	0.75
300	1.16	1.09	1.00	0.89	0.81	0.75
400	1.16	1.09	1.00	0.89	0.81	0.75
500	1.16	1.09	1.00	0.89	0.81	0.75

**Table 4.7: Rating factors for variations in soil thermal resistivities for three-core 22 kV and 33 kV cables laid direct in ground**

Nominal area of conductor mm <sup>2</sup>	Values of soil thermal resistivity K.m/W					
	1.0	1.2	1.5	2.0	2.5	3.0
35	1.14	1.08	1.00	0.90	0.83	0.77
50	1.14	1.08	1.00	0.90	0.83	0.77
70	1.14	1.08	1.00	0.90	0.83	0.77
95	1.14	1.08	1.00	0.90	0.83	0.77
120	1.14	1.08	1.00	0.90	0.82	0.76
150	1.15	1.08	1.00	0.90	0.82	0.76
185	1.15	1.08	1.00	0.90	0.82	0.76
240	1.15	1.08	1.00	0.90	0.82	0.76
300	1.15	1.08	1.00	0.90	0.82	0.76
400	1.16	1.09	1.00	0.89	0.82	0.76
500	1.16	1.09	1.00	0.89	0.82	0.75
500	1.16	1.09	1.00	0.89	0.81	0.75

**Table 4.8 Group rating factors for circuits of three single-core 3.3, 6.6, 11, 22 & 33 kV cables laid direct in the ground**

Number of Circuits	Spacing between group centres mm				
	Touching	200	400	600	800
2	0.73	0.83	0.88	0.90	0.92
3	0.60	0.73	0.79	0.83	0.86
4	0.54	0.68	0.75	0.80	0.84
5	0.49	0.63	0.72	0.78	0.82
6	0.46	0.61	0.70	0.76	0.81
7	0.43	0.58	0.68	0.75	0.80
8	0.41	0.57	0.67	0.74	
9	0.39	0.55	0.66	0.73	
10	0.37	0.54	0.65		
11	0.36	0.53	0.64		
12	0.35	0.52	0.64		

**Table 4.9 Group rating factors for three-core 3.3, 6.6, 11, 22 & 33 kV cables in horizontal formation laid direct in the ground**

Number of Circuits	Spacing between cable centres mm				
	Touching	200	400	600	800
2	0.80	0.86	0.90	0.92	0.94
3	0.69	0.77	0.82	0.86	0.89
4	0.62	0.72	0.79	0.83	0.87
5	0.57	0.68	0.76	0.81	0.85
6	0.54	0.65	0.74	0.80	0.84
7	0.51	0.63	0.72	0.78	0.83
8	0.49	0.61	0.71	0.78	
9	0.47	0.60	0.70	0.77	
10	0.46	0.59	0.69		
11	0.45	0.57	0.69		
12	0.43	0.56	0.68		

**Table 4.10 Group rating factors for three-core 3.3, 6.6, 11, 22 & 33 kV cables in air on perforated trays**

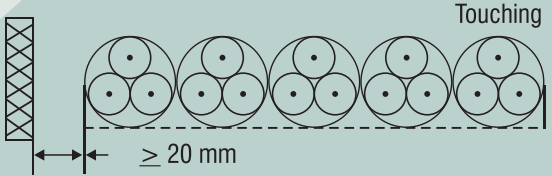
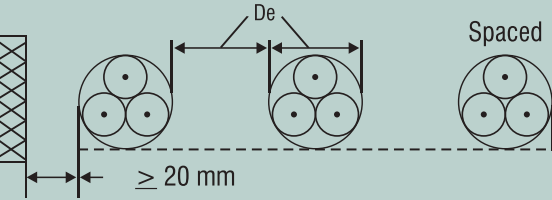
Number of Trays	Number of Cables					
	1	2	3	4	6	9
 <p>Touching</p>	1.00	0.88	0.82	0.79	0.76	0.73
	2	0.87	0.80	0.77	0.73	0.68
	3	0.86	0.79	0.76	0.71	0.66
 <p>Spaced</p>	1.00	1.00	0.98	0.95	0.91	
	2	0.99	0.96	0.92	0.87	
	3	0.98	0.95	0.91	0.85	

NOTE: 1 Factors apply to single layer groups of cables as shown above. Factors for cables installed in more than one layer touching each other will be significantly lower and must be determined by an appropriate method.

NOTE: 2 Factors are given for vertical spacings between trays of 300 mm and at least 20 mm between trays and wall.

For closer spacing, the factors should be reduced.

**Table 4.11 Group rating factors for three-core 3.3, 6.6, 11, 22 & 33 kV cables in air on ladder supports, cleats, etc**

Number of Trays	Number of Cables					
	1	2	3	4	6	9
1	1.00	0.87	0.82	0.80	0.79	0.78
	2	0.86	0.80	0.78	0.76	0.73
3	1.00	0.85	0.79	0.76	0.73	0.70
2	1.00	1.00	1.00	1.00	1.00	
	2	0.99	0.98	0.97	0.96	
3	1.00	0.98	0.97	0.97	0.93	

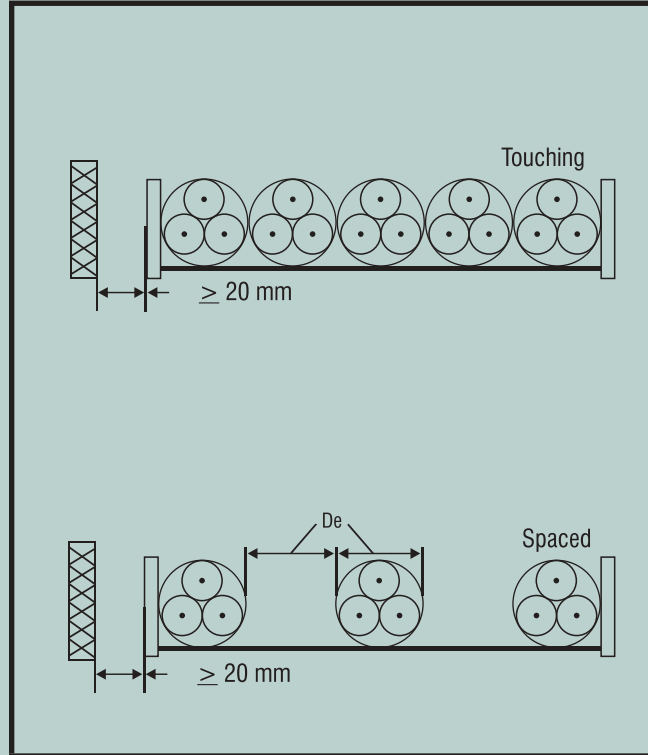

NOTE: 1 Factors apply to single layer groups of cables as shown above. Factors for cables installed in more than one layer touching each other will be significantly lower and must be determined by an appropriate method.

NOTE: 2 Factors are given for vertical spacings between trays of 300 mm and at least 20 mm between trays and wall.

For closer spacing, the factors should be reduced.

**Table 4.12 Group rating factors to be applied for circuits of three single core 3.3, 6.6, 11, 22 & 33 kV cables in air flat touching**

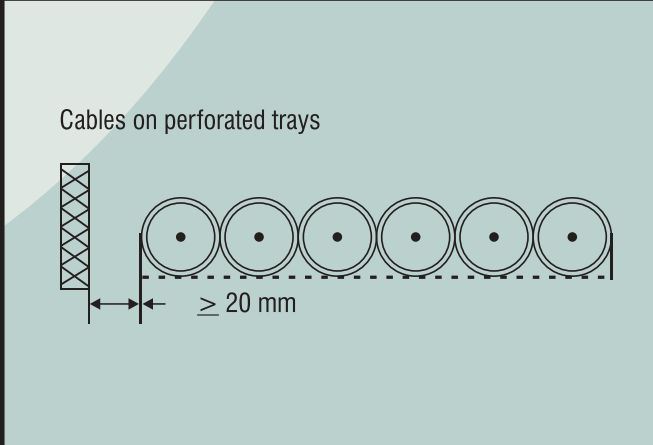
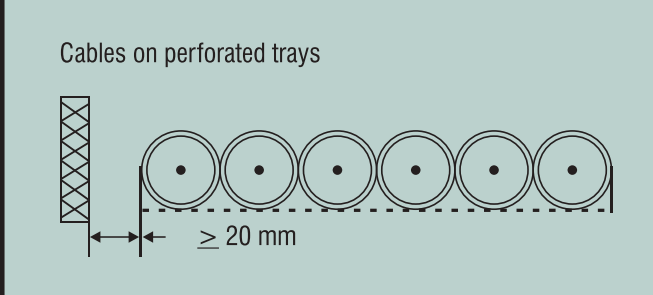
 <p>Cables on perforated trays</p>	Number of Trays	Number of three - phase circuits		
		1	2	3
		0.98	0.91	0.87
	2	0.96	0.87	0.81
	3	0.95	0.85	0.78
		1.00	0.97	0.96
 <p>Cables on perforated trays</p>	2	0.98	0.93	0.89
	3	0.97	0.90	0.86

NOTE: 1 Factors are given for single layers of cables as shown above. Factors for cables installed in more than one layer touching each other will be significantly lower and must be determined by an appropriate method.

NOTE: 2 Factors are given for vertical spacings between trays of 300 mm and at least 20 mm between trays and wall. For closer spacing, the factors should be reduced. NOTE: 3 For circuits having more than one cable in parallel per phase, each three phase set of conductors should be considered as a circuit for the purpose of this table.

**Table 4.13: Rating factors for variations in soil thermal resistivities for three single-core 11DOV cables laid direct in ground**

Nominal area of conductor mm <sup>2</sup>	Values of soil thermal resistivity K.m/W					
	1.0	1.2	1.5	2.0	2.5	3.0
1.5	1.14	1.07	1.00	0.89	0.80	0.75
2.5	1.17	1.08	1.00	0.89	0.80	0.75
4	1.17	1.09	1.00	0.88	0.79	0.73
6	1.17	1.09	1.00	0.88	0.79	0.73
10	1.18	1.09	1.00	0.88	0.79	0.73
16	1.18	1.10	1.00	0.88	0.79	0.72
25	1.19	1.10	1.00	0.88	0.79	0.72
35	1.19	1.10	1.00	0.88	0.79	0.72
50	1.19	1.10	1.00	0.88	0.79	0.72
70	1.20	1.11	1.00	0.88	0.79	0.72
95	1.20	1.11	1.00	0.87	0.79	0.72
120	1.20	1.11	1.00	0.87	0.79	0.72
150	1.20	1.11	1.00	0.87	0.79	0.72
185	1.20	1.11	1.00	0.87	0.78	0.72
240	1.20	1.11	1.00	0.87	0.78	0.72
300	1.20	1.11	1.00	0.87	0.78	0.72
400	1.20	1.11	1.00	0.87	0.78	0.72
500	1.21	1.11	1.00	0.87	0.78	0.72
630	1.21	1.11	1.00	0.87	0.78	0.72
800	1.21	1.11	1.00	0.87	0.78	0.72
1000	1.21	1.11	1.00	0.87	0.78	0.72

**Table 4.14: Rating factors for variations in soil thermal resistivities for multi-core 11DOV cables laid direct in ground**

Nominal area of conductor mm <sup>2</sup>	Values of soil thermal resistivity K.m/W					
	1.0	1.2	1.5	2.0	2.5	3.0
1.5	1.14	1.08	1.00	0.90	0.83	0.77
2.5	1.15	1.08	1.00	0.90	0.82	0.76
4	1.15	1.08	1.00	0.89	0.82	0.76
6	1.16	1.09	1.00	0.89	0.81	0.75
10	1.16	1.09	1.00	0.89	0.81	0.75
16	1.17	1.09	1.00	0.89	0.80	0.74
25	1.18	1.09	1.00	0.89	0.80	0.74
35	1.18	1.10	1.00	0.88	0.80	0.74
50	1.18	1.10	1.00	0.88	0.80	0.74
70	1.18	1.10	1.00	0.88	0.80	0.74
95	1.18	1.10	1.00	0.88	0.80	0.73
120	1.18	1.10	1.00	0.88	0.80	0.73
150	1.18	1.10	1.00	0.88	0.80	0.73
185	1.19	1.10	1.00	0.88	0.80	0.73
240	1.19	1.10	1.00	0.88	0.80	0.73
300	1.19	1.10	1.00	0.88	0.80	0.73
400	1.19	1.10	1.00	0.88	0.80	0.73
500	1.19	1.10	1.00	0.88	0.80	0.73
630	1.19	1.10	1.00	0.88	0.80	0.73
800	1.21	1.11	1.00	0.87	0.78	0.72
1000	1.21	1.11	1.00	0.87	0.78	0.72

**Table 4.15: Group Rating factors for circuits of three single-core cables 1100V laid direct in the ground, horizontal formation**

Number of Circuits	Spacing between group centres mm				
	Touching	150	300	450	600
2	0.77	0.81	0.86	0.88	0.89
3	0.67	0.71	0.78	0.81	0.83
4	0.61	0.64	0.72	0.76	0.80
5	0.57	0.60	0.69	0.74	0.77
6	0.53	0.57	0.66	0.72	0.75
7	0.51	0.55	0.64	0.70	0.74
8	0.49	0.53	0.63	0.69	0.73
9	0.47	0.52	0.62	0.68	0.73
10	0.45	0.51	0.61	0.67	0.72
11	0.44	0.50	0.60	0.66	0.72
12	0.43	0.49	0.59	0.65	0.71

**Table 4.16: Group Rating factors for multi-core 1100V cables laid direct in the ground, in tier formation**

Number of cables	Number of Circuits	Spacing between cable centres mm				
		Touch-ing	150	300	450	600
2	1	0.80	0.84	0.87	0.90	0.91
3	1	0.68	0.74	0.79	0.83	0.86
4	2	0.60	0.66	0.73	0.77	0.79
5	2	0.55	0.61	0.68	0.71	0.73
6	2	0.51	0.57	0.63	0.67	0.69
7	3	0.48	0.54	0.59	0.63	0.64
8	3	0.46	0.51	0.56	0.60	0.61
9	3	0.44	0.48	0.53	0.57	0.58
10	4	0.42	0.47	0.52	0.55	0.56
11	4	0.41	0.46	0.50	0.54	0.55
12	4	0.40	0.45	0.49	0.53	0.54

**Table 4.17 Group rating factors for multi-core 1100V cables in air on perforated trays**

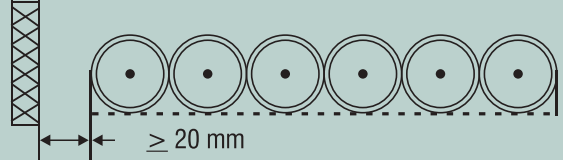
Cables on perforated trays	Number of Trays	Number of Cables					
		1	2	3	4	6	9
 <p>Cables on perforated trays</p> <p><math>\geq 20</math> mm</p>	1	1.00	0.88	0.82	0.79	0.76	0.73
	2	1.00	0.87	0.80	0.77	0.73	0.68
	3	1.00	0.86	0.79	0.76	0.71	0.66
 <p>Spaced</p> <p><math>\geq 20</math> mm</p> <p><math>D_e</math></p>	1	1.00	1.00	0.98	0.95	0.91	
	2	1.00	0.99	0.96	0.92	0.87	
	3	1.00	0.98	0.95	0.91	0.85	

NOTE: 1 Factors apply to single layer groups of cables as shown above. Factors for cables installed in more than one layer touching each other will be significantly lower and must be determined by an appropriate method.

NOTE: 2 Factors are given for vertical spacings between trays of 300 mm and at least 20 mm between trays and wall. For closer spacing, the factors should be reduced.

Table 4.18 Group rating factors for multi-core 11DOV cables in air on vertical perforated trays

Number of Trays	Number of Cables					
	1	2	3	4	6	9
1	1.00	0.88	0.82	0.78	0.73	0.72
	2	1.00	0.88	0.81	0.76	0.70
3	1.00	0.91	0.89	0.88	0.87	
	1.00	0.91	0.88	0.87	0.85	

NOTE: 1 Factors are given for horizontal spacing between trays of 225 mm with trays mounted back to back. For closer spacing, the factors should be reduced.

**Table 4.19 Group rating factors for multi-core 11DOV cables in air on ladder supports, cleats, etc**

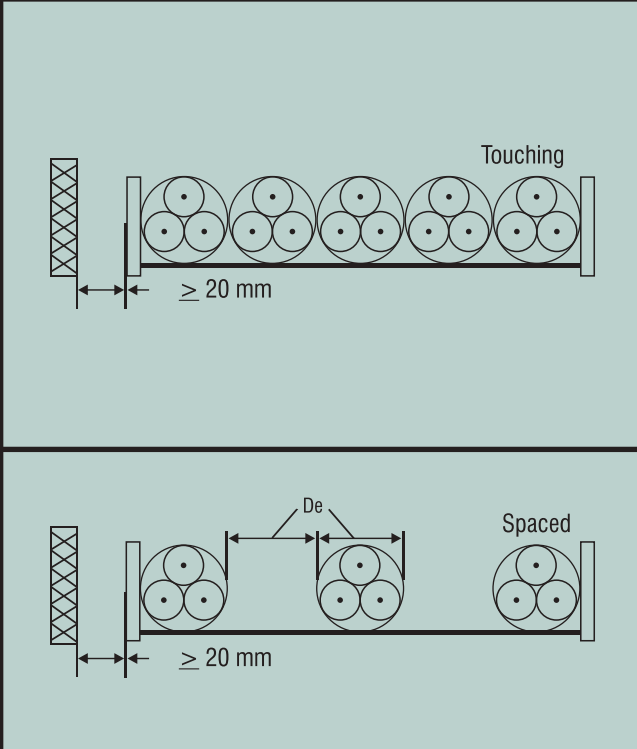
	Number of Trays	Number of Cables					
		2	3	4	6	9	
Touching	1	1.00	0.88	0.82	0.79	0.76	0.73
	2	1.00	0.87	0.80	0.77	0.73	0.68
	3	1.00	0.86	0.79	0.76	0.71	0.66
Spaced	1	1.00	1.00	1.00	1.00	1.00	
	2	1.00	0.99	0.98	0.97	0.96	
	3	1.00	0.98	0.97	0.96	0.93	

NOTE: 1 Factors apply to single layer groups of cables as shown above. Factors for cables installed in more than one layer touching each other will be significantly lower and must be determined by an appropriate method.

NOTE: 2 Factors are given for vertical spacings between trays of 300 mm and at least 20 mm between trays and wall. For closer spacing, the factors should be reduced.



# TYPICAL FLOW CHART OF FINVUL-X AND FINOPOWER XLPE CABLES AS PER IS: 7098 - (PART - I & II)

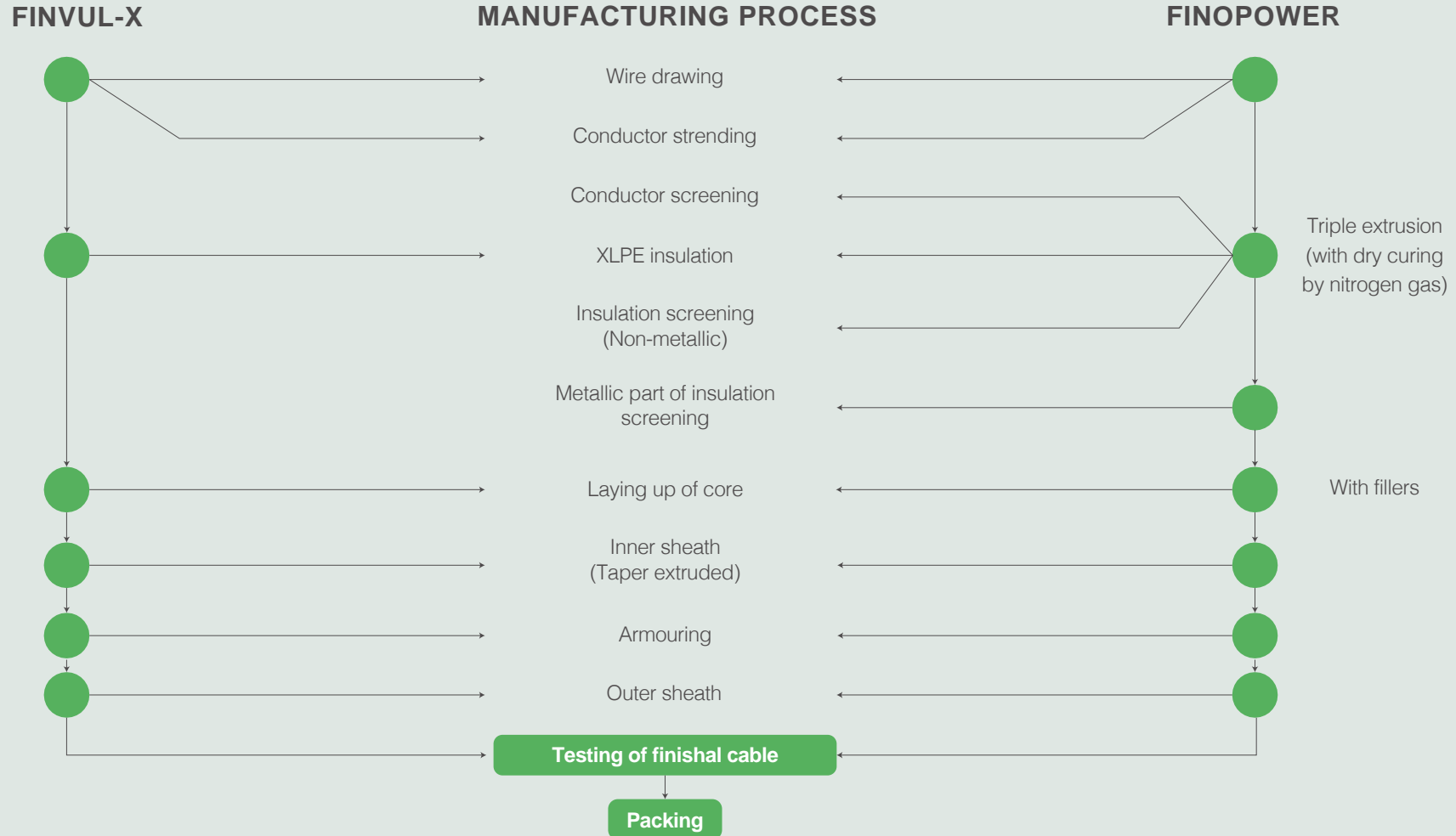

## MATERIALS :

- Aluminium / Copper
- Semi-conducting compound
- XLPE insulation
- Annealed copper tape
- Non-hygroscopic filler armour
- Galvanised steel

# RECOMMENDATIONS FOR STORAGE AND INSTALLATION OF CABLES

## HANDLING AND STORAGE

Handling at site: While unloading the cable drums certain precautions are to be taken for ensuring the safety of the cable.

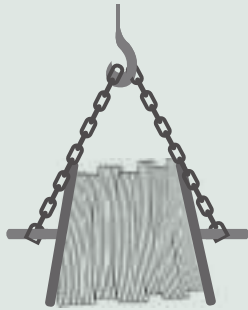

WRONG

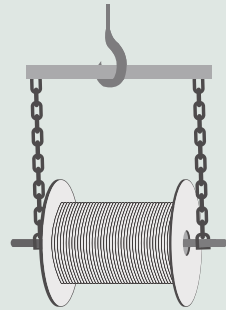

CORRECT

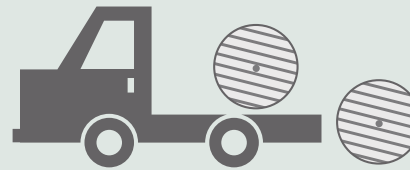

WRONG

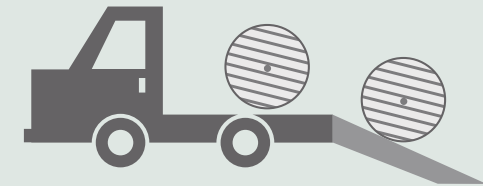

CORRECT

When using a lift or crane use a spreader bar longer than the overall drum width, just above the drum flanges. Without a spreader bar this will lead to bending of drum flanges crushing and damaging the cable.

When unloading from the truck, an inclined ramp should be used to lower the drum. Do not drop the drum directly from the truck as it may lead to the damage of the drum and subsequently the cable.

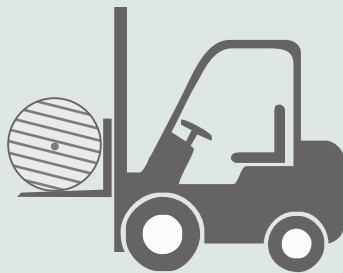

WRONG

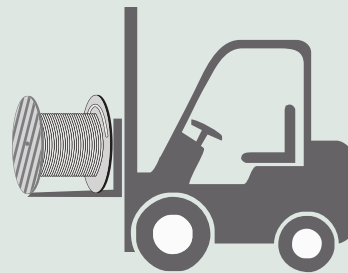

CORRECT

While using forklift for handling or shifting the drum, the drum should be perpendicular to the forks, rather than parallel. Do not allow the forks to be in contact with the cable.

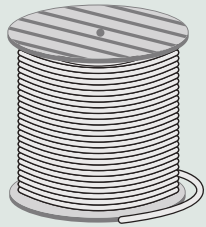

WRONG

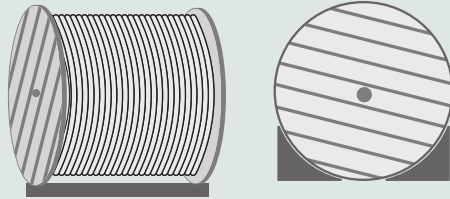

CORRECT

### INSTALLATION AND LAYING

While laying of cables special care has to be taken. The cable end should be pulled with pulling eye only after mounting the drum on the jacks. Do not keep the drum on its flange while pulling the cable. This will result in bird caging (twists and deformation of cable) and armour swelling.

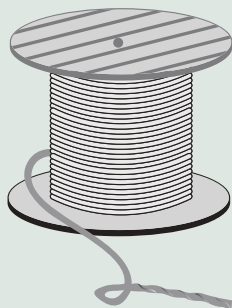

WRONG

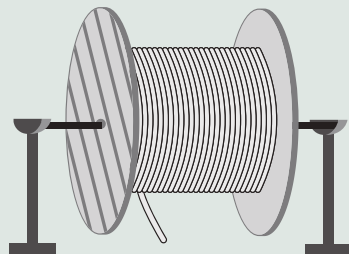

CORRECT

### STORAGE

Cable drums should be stored on plain ground without any hard stones projecting above the surface and dry place away from direct sunlight and rain . All cable drums should be stored with the battens intact, with sufficient space in between the drums. Ensure stoppers for every drum to avoid the drum movement after storage. Cable drums should not be stored one above the other.

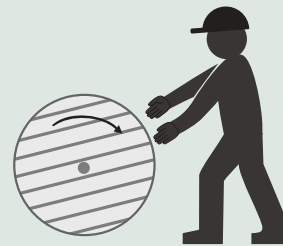

WRONG

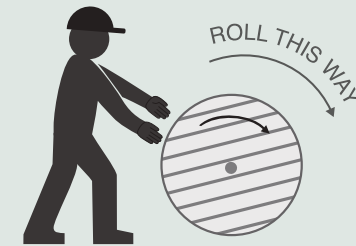

CORRECT

#### Minimum Bending Radius:

Cable Type	Single Core	Multi Core
HT Cable	20xD	15xD
LT Cable	15xD	12xD

### TESTING AT SITE

After the cable is installed before commissioning, it should be tested for DC High voltage. The recommended voltage and duration will be as per IS:1255. Megger, continuity and cross continuity to be checked on each core before and after laying.



Send us a Hi!  
on **2027506219**  
to register your  
complaint.

**Finolex**  
:DELIGHT

Customer Care  
1800-209-0166  
customer care@finolex.com

**Finolex**  
Cables Limited

AN IS/ISO 9001:2015 CERTIFIED COMPANY

26-27, Mumbai-Pune Road, Pimpri, Pune - 411018, India. Tel: 020-27506200 | Fax: 020 27470344 | Visit us at: [www.finolex.com](http://www.finolex.com) | Email: [sales@finolex.com](mailto:sales@finolex.com) | CIN: L31300MH1967PLC016531



[/finolexcables](https://www.facebook.com/finolexcables)



[/finolexcables](https://twitter.com/finolexcables)



[/finolex.Cables](https://www.instagram.com/finolex.Cables)

FOR TECHNICAL LITERATURE PLEASE CONTACT OUR BRANCH OFFICES: Ahmedabad: Tel: 079-26584637, 26575639 Fax: 26575743 | Bangalore: Tel: 080-25320176 | Bhubaneswar: Tel: 0674-2530053 | Chennai: Tel: 044-28231514, 28269322, 28284142, 28230341 Fax: 28265768 | Chandigarh: Tel: 0172-5076631, 2637334 | Cochin: Tel: 0484-2408930, 2408492 Fax: 2539107 | Coimbatore: Tel: 0422-2233939, 2333940, 2330997 | Dharwad: Tel: 0836-2746440 | Goa: Tel: 0832 - 2782003, 2782065 Fax : 2783909 | Guwahati: Tel: 0361-2490067, 2410955 | Indore: Tel: 0731-2802646 | Jaipur: Tel : 0141-2332526/29 | Kolkata: Tel: 033-24192494, 24192495 | Lucknow: Tel: 0522-2439815, 4035031 | Mumbai: Tel: 022-22873252, 22820062 Fax: 22852168 | New Delhi: Tel: 011-23715642, 23324748, 3353103, 23353160 | Patna: Tel: 0612-2920185 | Pune: Tel: 020-27475963, 27506200 Fax: 27470344 | Raipur: Tel: 0771-2885595 Fax: 2525800 | Ranchi: Tel: 0651-2284758 | Roorkee: Tel: 01332-224068 Fax: 224069 | Secunderabad: Tel: 040-27721224, 27846988 Fax: 27817463 | Vijayawada: Tel: 0866-2412599

ALL INFORMATION GIVEN HEREIN IS IN GOOD FAITH. FINOLEX SHALL NOT BE LIABLE FOR ANY DAMAGES ARISING OUT OF INCORRECT USE OR INTERPRETATION.

In order to derive maximum benefit and utilisation of our products, we advise that these products are stored, installed and commissioned as per the norms prevailing in the place of installation. When decommissioned, these should be disposed using appropriate methods/process specified in respective state / location of use so as not to affect the environment adversely.

# FTTH Cables

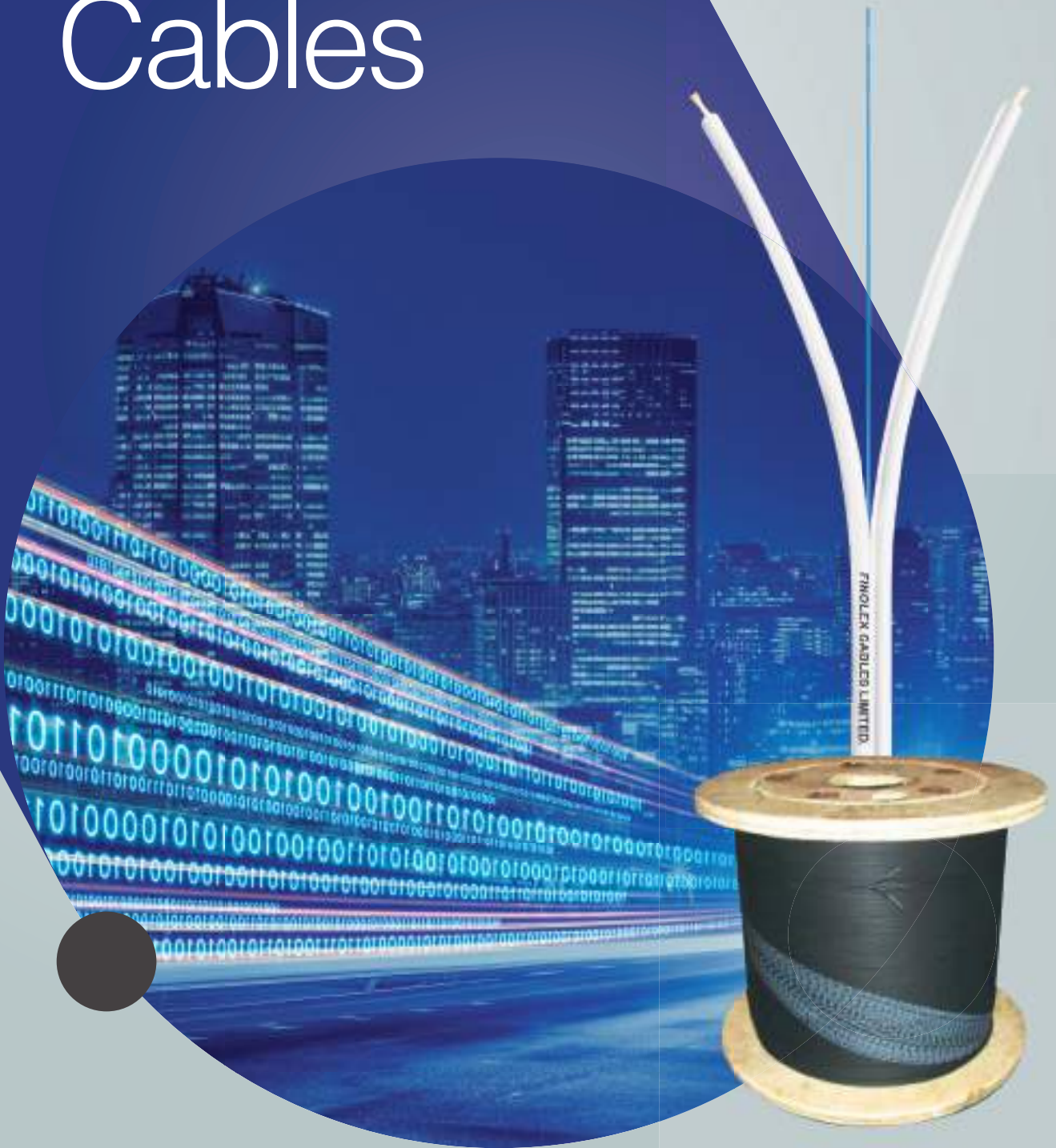

# FINOLEX CABLES LIMITED

Started in 1958, Finolex Cables Limited is India's largest leading Electrical and Telecommunication cables manufacturer. Finolex Cables has always believed in enhancing its capabilities and augmenting the product basket. In last few years, besides the cable business, the company has forayed into new segments and added new products under Finolex brand name. The company offers Total Electrical Solutions with products like Industrial / Electrical Wires, Flexible Cables, Elevator Cables, 3 Core Flat Cables, Auto Cables, Communication Cables, Telecommunication Cables, Power Cables, Copper Rods, LED Lighting Range, Premium Modular Switches, Switchgear, Water Heaters and elegant looking domestic Fans. Finolex Cables Limited has four manufacturing facilities viz. at Pimpri (Pune), Urse (near Pune), Verna (Goa) and Roorkee (Uttarakhand).

## WHY FINOLEX?

- More than 55 years of trust • Virgin raw materials hence longer life & premium quality products • Wide range of cables.
- In-house production of genuine & world-class Optical Fibre • India's only company with patented technology from OFS, USA for Unitube Cables.

## FTTH CABLES

1 or 2 fibres are placed in LSZH/PVC sheath in between two ARP / FRP rods which can be taken out easily from the sheath. The optical fibre used is bend insensitive fibre which is suitable in FTTH network for indoor application.

Cable Description	: 1F/2F Drop Cable for FTTH Application		
Type of Fibre	: Single Mode G.657 A1 / A2		
Cable Construction Details			
No. of Fibres	: 1F or 2F as per requirement		
Fibre Colour	: Blue, Orange		
Strength Member	: Aramid Reinforced Plastic (ARP) / FRP Rod - 2 Nos.		
Outer Sheath	: Low Smoke Zero Halogen or PVC		
Sheath Colour	: Black / White & Translucent		
<b>Optical Characteristics for G.657 A Fibres</b>			
<b>Attenuation</b> 1310nm :	≤ 0.4 dB/Km	Cable cutoff wavelength	: ≤1260nm
	1550nm :	≤ 0.3 dB/Km	Mode Field Diameter @1310nm : 8.6 - 9.5µm (±0.4 µm)
<b>Fibre Geometry</b>			
Coating diameter :	245 ± 10µm	Cladding Non-circularity	: ≤ 1%
Cladding diameter :	125 ± 1µm	Mode Field Concentricity Error	: ≤ 0.8µm
Cable Mechanical Characteristics		Physical Characteristics	
Tensile Strength :		Cable Dimensions	
Installation :	100 N	Width :	3.1 ± 0.2 mm
Operation :	50 N	Height :	2 ± 0.2 mm
Minimum Bending radius :	20 mm	Nominal Cable Weight :	9.5 Kg/km (Nomianl)
Crush Resistance :	500N/100X100	Cable Length Per Drum / Coil :	500 Meter to 2000 Meter
<b>Printing:</b>	The jacket will be marked with contrast color inkjet printing at the intervals of every meter. Details as per requirement.		
<b>Shipping:</b>	Cable shall be shipped on reels / coils packed in corrugated boxes.		

Note: Translucent material is not fire retardant



Outer Sheath

ARP / FRP

Optical Fibre

### Advantages

- All di-electric cable
- Simple and fast installation
- Easy for termination
- Light weight
- Self supporting
- Low bend radius

# Finolex

## Cables Limited

AN IS/ISO 9001 CERTIFIED COMPANY

26-27, Mumbai-Pune Road, Pimpri, Pune - 411018, India.  
Tel: 020-27506200 | Visit us at: www.finolex.com  
Email: sales@finolex.com  
CIN: L31300MH1967PLC016531

FOR TECHNICAL LITERATURE PLEASE CONTACT OUR BRANCH OFFICES: Ahmedabad : Tel: 079-26584637 / 26575639 | Bengaluru : Tel: 9845278680 | Bhubaneswar : Tel: 0674-2971188, 2971922 | Chennai : Tel: 044-28231514/28284141 | Chandigarh : Tel: 9316064670 | Cochin : Tel: 9880088155 | Coimbatore : Tel: 0422-2330997 | Dharwad : Tel: 9880088155 | Goa : Tel: 0832-2782003 / 2782065 | Gurgaon : Tel: 9896763770 | Guwahati : Tel: 9435324398 | Indore : Tel: 7314911723 | Jaipur : Tel: 9929111411 | Kolkata : Tel: 0522-4035031 | Lucknow : Tel: 9560299393 | Mumbai : Tel: 022 - 22820062 | New Delhi : Tel: 9870170171 | Patna : Tel: 9934107999 | Pune : Tel: 020 - 27506200 | Raipur : Tel: 7008336581 | Ranchi : Tel: 8101383841 | Secunderabad : Tel: 040 - 27811161 | Uttarakhand : Tel: 9760045003 | Vadodara : Tel: 9879555568 | Vijayawada : Tel: 9848043967



/finolexcables



/finolexcables



/finolex.cables

ALL INFORMATION GIVEN HEREIN IS IN GOOD FAITH. FINOLEX SHALL NOT BE LIABLE FOR ANY DAMAGES ARISING OUT OF INCORRECT USE OR INTERPRETATION. In order to derive maximum benefit and utilisation of our products, we advise that these products are stored, installed and commissioned as per the norms prevailing in the place of installation. When decommissioned, these should be disposed using appropriate methods/process specified in respective state / location of use so as not to affect the environment adversely. While every effort has been taken to guarantee that all details and portrayals are correct, this leaflet should not be viewed as a definitive guide or as a proposal of sales for a specific product. Due to variable factors in the production process, shades of the actual product might fluctuate marginally from those portrayed. Model numbers and particulars are for reference purposes only. May subject to change without prior notice.

# Speaker Cables



**25 METER  
PACKING  
AVAILABLE**

## FINOLEX CABLES LIMITED

Started in 1958, Finolex Cables Limited is India's largest leading electrical and telecommunication cables manufacturer. Finolex Cables has always believed in enhancing its capabilities and augmenting the product basket. In last few years, besides the cables business the company has forayed into new segments and added new products under the Finolex brand. The company offers Total Electrical Solutions with products like Electrical Wires, 3 Core Flat Cables, Communication Cables, Telecommunication Cables, Flexible Cables, Auto Cables, Conduits, Room Heaters, LED Lights, Switches, Switchgears, Fans, Irons and Water Heaters.

Finolex Cables Limited has four manufacturing facilities viz. at Pimpri (Pune), Urse (near Pune), Verna (Goa) and Roorkee (Uttarakhand). The company is known for its unmatched quality and safety standard which has made it amongst the most reliable brands of the country. Over the six-decade long journey, Finolex Cables has cemented its reputation as an innovative leader and quality manufacturer by continuously upgrading technology, modernizing manufacturing facilities and maintaining the highest standards in quality and service.

# SPEAKER CABLES

Finolex twin parallel type speaker cables are manufactured with multi wire, bright annealed flexible bare electrolytic grade conductor, insulated with specially formulated transparent grade PVC compound. These speaker cables offer extra flexibility and hence find very easy to pull through the conduit without damage. For easy identification, one of the cores is marked with red colour strip all along the length of the cable. The distance between the two conductors is maintained consistently for uniform capacitance throughout the length. The cables being transparent offer good aesthetic value. These are mainly used in connecting speakers, used in public address systems installed in large residential complexes, (as per new Building Code) for clear and distortion-free voice with very low db loss. These are available in 20, 19, 18, 16, 14, and 13 AWG conductor sizes with 100 meters and 25 meters coil packing.

## TECHNICAL DETAILS

Conductor			Approximate Overall Dimensions (mm)			
Size AWG	Nominal Area Of Cond. (sq.mm)	Max. Cond. Resistance ohms/km 20 °C	Max Width (mm)	Max Height (mm)	Thickness (nom)	Web Dims. W x H
20	0.5	39.0	4.45	2.00	0.6	0.5 x 0.4
19	0.75	26.00	5.45	2.50	0.6	0.5 x 0.4
18	1.0	21.4	6.05	2.80	0.7	0.5 x 0.4
16	1.5	13.3	6.25	2.90	0.7	0.5 x 0.4
14	2.0	9.00	7.00	3.30	0.75	0.5 x 0.4
13	2.5	7.98	7.4	3.45	0.75	0.5 x 0.4

## SPEAKER CABLE SELECTION CHART

	4 Ohm Speaker			8 Ohm Speaker		
	Power loss in %	11	21	50	11	21
loss in db	0.5	1.0	3.0	0.5	1.0	3.0

	Max. Distance in Mtrs.					
	20 AWG	19 AWG	18 AWG	16 AWG	14 AWG	13 AWG
8	16	60	16	32	119	
10	21	85	21	65	170	
12	27	103	26	58	208	
18	38	143	35	76	285	
27	59	226	56	120	451	
34	74	282	71	151	564	

We can use this table for the selection of the cable. An example is shown below:

For 14 AWG cable in 8 Ohm speaker system with power loss of 21% (1.0db) maximum length will be 120 mtrs.

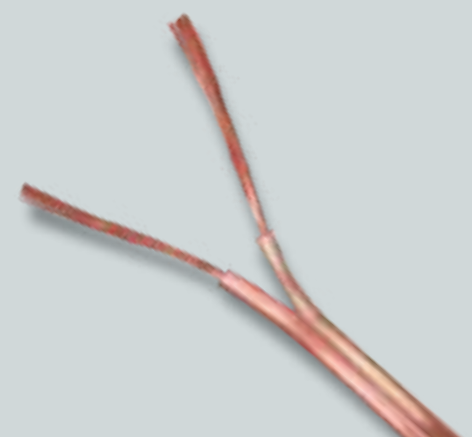
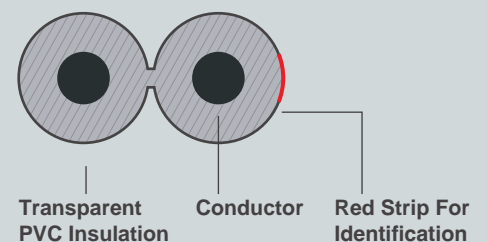

# Finolex Cables Limited

AN IS/ISO 9001 CERTIFIED COMPANY

26-27, Mumbai-Pune Road, Pimpri, Pune - 411018, India.  
Tel: 020-27506200 | Visit us at: www.finolex.com  
Email: sales@finolex.com  
CIN: L31300MH1967PLC016531

FOR TECHNICAL LITERATURE PLEASE CONTACT OUR BRANCH OFFICES: Ahmedabad : Tel: 079-26584637 / 26575639 | Bengaluru : Tel: 9845278680 | Bhubaneswar : Tel: 0674-2971188, 2971922 | Chennai : Tel: 044-28231514/28284141 | Chandigarh : Tel: 9316064670 | Cochin : Tel: 9880088155 | Coimbatore : Tel: 0422-2330997 | Dharwad : Tel: 9880088155 | Goa : Tel: 0832-2782003 / 2782065 | Gurgaon : Tel: 9896763770 | Guwahati : Tel: 9435324398 | Indore : Tel: 7314911723 | Jaipur : Tel: 9929111411 | Kolkata : Tel: 0522-4035031 | Lucknow : Tel: 9560299393 | Mumbai : Tel: 022 - 22820062 | New Delhi : Tel: 9870170171 | Patna : Tel: 9934107999 | Pune : Tel: 020 - 27506200 | Raipur : Tel: 7008336581 | Ranchi : Tel: 8101383841 | Secunderabad : Tel: 040 - 27811161 | Uttarakhand : Tel: 9760045003 | Vadodara : Tel: 9879555568 | Vijayawada : Tel: 9848043967

[f /finolexcables](#) [t /finolexcables](#) [i /finolex.cables](#)

ALL INFORMATION GIVEN HEREIN IS IN GOOD FAITH. FINOLEX SHALL NOT BE LIABLE FOR ANY DAMAGES ARISING OUT OF INCORRECT USE OR INTERPRETATION. In order to derive maximum benefit and utilisation of our products, we advise that these products are stored, installed and commissioned as per the norms prevailing in the place of installation. When decommissioned, these should be disposed using appropriate methods/process specified in respective state / location of use so as not to affect the environment adversely. While every effort has been taken to guarantee that all details and portrayals are correct, this leaflet should not be viewed as a definitive guide or as a proposal of sales for a specific product. Due to variable factors in the production process, shades of the actual product might fluctuate marginally from those portrayed. Model numbers and particulars are for reference purposes only. May subject to change without prior notice.

# CAT 6 ECCS Tape Armoured Cable



## CAT 6 ECCS TAPE ARMoured CABLE

The cable construction & electrical performance of the 4 Pair 23 AWG CAT-6 Corrugated ECCS Tape Armoured Cable with polyethylene outer sheath provides extra mechanical protection and hence can be used for underground and outdoor application.

### REFERENCE SPECIFICATION

ANSI/TIA-568-C.2 and ISO/IEC 11801 Standard.

### PRODUCT APPLICATION:

- 10 Base T (IEEE 802.3),
- 100 Base T (IEEE 802.3U)
- 1000 BASE-T (IEEE 802.3ab)
- 1000 BASE-TX
- TP-PMD (ANSI X3T9.5) 100 Mbps CDDI
- ATM 155
- 4/16 Mbps Token Ring (IEEE 802.5)
- Meets IEEE802.3af & 802.3at PoE

### CROSS SECTIONAL DIAGRAM

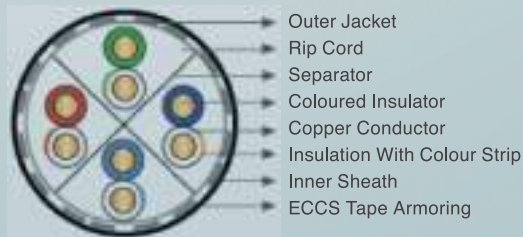

Actual Image

# PRODUCT SPECIFICATIONS

Conductor	:	Annealed Bare Copper, 23AWG
Insulation	:	High Density Polyethylene (HDPE)
Colour Code	:	<b>Pair Colour Code Of Cores</b> 1 White Blue – Blue 2 White Orange – Orange 3 White Green – Green 4 White Brown – Brown
Separator	:	Polyethylene Central Cross Filler
Rip Cord	:	Nylon Rip Cord Under Inner Sheath
Inner Sheath	:	PVC
Inner Sheath Diameter	:	6.0 ± 0.3mm
Armoring	:	Electro Chromium Coated Corrugated Steel Tape Over PVC Sheathed Cable.
Outer Sheath	:	Polyethylene
Colour	:	Black
Diameter (Approx.)	:	9.2 mm
Standard Packing Length	:	305 m on Wooden Drum Or As Per Customer's Requirement.

Electrical Properties Per 100 Meter At 20°C	
Impedance	100 ± 15 Ω @ 100 MHz
Conductor Resistance	≤9.38 Ω/100 m Max
Insulation Resistance	100 M Ω
Mutual Capacitance	<5.6 nF/100 m Max
Resistance Unbalance	5% Max
Capacitance Unbalance	Max. 330 pF/100m
Dielectric Strength	1.0 kV DC or 0.75 kV AC for 1 min
Delay Skew	<45 nS
NVP %	69%
Operating Voltage	72 V

## High Frequency Performance Tests On Fluke Analyzer (100 m On Channel Performance)

Frequency (MHz)	ATTN	RETURN LOSS	NEXT	PS NEXT	ELFEXT	PS ELFEXT	ACR	PSACR
	MAX	MIN	MIN	MIN	MIN	MIN	MIN	MIN
	dB/100m	(dB)	(dB)	(dB)	dB/100	dB/100m	(dB)	(dB)
1.00	2.0	20.0	74.3	72.3	67.8	64.8	72.3	70.3
4.00	3.8	23.0	65.3	63.3	55.8	52.8	61.5	59.5
8.00	5.3	24.5	60.8	58.8	49.7	46.7	55.5	53.5
10.00	6.0	25.0	59.3	57.3	47.8	44.8	53.3	51.3
16.00	7.6	25.0	56.2	54.2	43.7	40.7	48.6	46.6
20.00	8.5	25.0	54.8	52.8	41.8	38.8	46.3	41.3
25.00	9.5	24.3	53.3	51.3	39.8	36.8	43.8	41.8
31.25	10.7	23.6	51.9	49.9	37.9	34.9	41.2	39.2
62.50	15.4	21.5	47.4	45.4	31.9	28.9	32.0	30.0
100.0	19.8	20.1	44.3	42.3	27.8	24.8	24.5	22.5
200.0	29.0	18.0	39.8	37.8	21.8	18.8	10.8	8.8
250.0	32.8	17.3	38.3	36.3	19.8	16.8	5.5	3.5

# Finolex Cables Limited

AN IS/ISO 9001 CERTIFIED COMPANY

26-27, Mumbai-Pune Road, Pimpri, Pune - 411018, India.  
 Tel: 020-27506200 | Customer Care No.: 1800-209-0166  
 Visit us at: www.finolex.com | Email: sales@finolex.com  
 CIN: L31300MH1967PLC016531

FOR TECHNICAL LITERATURE PLEASE CONTACT OUR BRANCH OFFICES: Ahmedabad : Tel: 079-26584637 / 26575639 | Bengaluru : Tel: 9845278680 | Bhubaneswar : Tel: 0674-2971188, 2971922 | Chennai : Tel: 044-28231514 / 28284141 | Chandigarh : Tel: 9316064670 | Cochin : Tel: 9880088155 | Coimbatore : Tel: 0422-2330997 | Dharwad : Tel: 9880088155 | Goa : Tel: 0832-2782003 / 2782065 | Gurgaon : Tel: 9896763770 | Guwahati : Tel: 9435324398 | Indore : Tel: 7314911723 | Jaipur : Tel: 9929111411 | Kolkata : Tel: 0522-4035031 | Lucknow : Tel: 9560299393 | Mumbai : Tel: 022 - 22820062 | New Delhi : Tel: 9870170171 | Patna : Tel: 9934107999 | Pune : Tel: 020 - 27506200 | Raipur : Tel: 7008336581 | Ranchi : Tel: 8101383841 | Secunderabad : Tel: 040 - 27811161 | Uttarakhand : Tel: 9760045003 | Vadodara : Tel: 9879555568 | Vijayawada : Tel: 9848043967

 /finolexcables  /finolexcables  /finolex.cables

ALL INFORMATION GIVEN HEREIN IS IN GOOD FAITH. FINOLEX SHALL NOT BE LIABLE FOR ANY DAMAGES ARISING OUT OF INCORRECT USE OR INTERPRETATION. In order to derive maximum benefit and utilisation of our products, we advise that these products are stored, installed and commissioned as per the norms prevailing in the place of installation. When decommissioned, these should be disposed using appropriate methods/process specified in respective state / location of use so as not to affect the environment adversely.

# Telephone Cables



## FINOLEX CABLES LIMITED

Started in 1958, Finolex Cables Limited is India's largest and leading electrical and telecommunication cables manufacturer. Finolex Cables has always believed in enhancing capabilities and augmenting the product basket. In the last few years besides the cables business the company has forayed into new segments and added new products under the Finolex brand. The company offers Total Electrical Solutions with products like Electrical Wires, 3 Core Flat Cables, Communication Cables, Telecommunication Cables, Flexible Cables, Auto Cables, Conduits, Room Heaters, LED Lights, Switches, Switchgears, Fans, Irons and Water Heaters. Finolex Cables Limited has four manufacturing facilities at Pimpri (Pune), Urse (near Pune), Verna (Goa) and Roorkee (Uttarakhand).

The company is known for its unmatched quality and safety standards which has made it amongst the most reliable brands of the country. Over the six-decade long journey, Finolex Cables has cemented its reputation as an innovative leader and quality manufacturer by continuously upgrading technology, modernizing manufacturing facilities and maintaining the highest standards in quality and service.

## FINOLEX TELEPHONE CABLES

Finolex's twisted paired cables are best suited for telephone cabling applications. The conductor is made of solid annealed, electrolytic grade high conductivity bare copper. The conductor is insulated with special grade high-density polyethylene with different colours. The insulated cores are twisted with uniform lay to form pairs and are bunched together in such a manner so as to minimise cross talk. In 50 and 100 pair cables the units of 10 and 20 pairs respectively are identified with colour binders and stranded to form the laid-up cable. The laid-up cable is further jacketed with a grey colour fire retardant (FR) PVC specially formulated and manufactured in-house, with high oxygen and temperature index. The cables can be used for internal telephone wiring in high-rise buildings, offices, factories, hotels, residential complexes, etc. Stringent quality control at every stage, from raw material through manufacturing, up to the finished product guarantees high quality.

**SALIENT FEATURES:** ■ Low Attenuation ■ Low Crosstalk ■ Fire Retardant Jacket in Grey

Construction Parameters		1 Pair	2 Pair	3 Pair	4 Pair	5 Pair	10 Pair	20 Pair	50 Pair	100 Pair
Conductor (Solid annealed bare copper)		0.4 mm diameter (nom.) & 0.5 mm diameter (nom.)								
Insulation Material (0.4 & 0.5 mm dia.)		High density polyethylene								
Insulation Thickness (Average)		0.4 mm dia. 0.5 mm dia.		0.17 mm 0.20 mm						
Diameter of Insulated Conductor(Maximum)		0.4 mm dia. 0.5 mm dia.		0.74 mm 0.92 mm						
Rip cord (0.4 & 0.5 mm dia.)		Nylon - placed under Jacket for Jacket stripping								
Colour Combination		For 0.4 mm dia. & 0.5 mm dia.								
Pair 1	White-Blue	White-Blue	White-Blue	White-Blue	White-Blue	White-Blue	White-Blue	White-Blue	White-Blue	White-Blue
Pair 2	-	White-Orange	White-Orange	White-Orange	White-Orange	White-Orange	White-Orange	White-Orange	White-Orange	White-Orange
Pair 3	-	-	White-Green	White-Green	White-Green	White-Green	White-Green	White-Green	White-Green	White-Green
Pair 4	-	-	-	White-Brown	White-Brown	White-Brown	White-Brown	White-Brown	White-Brown	White-Brown
Pair 5	-	-	-	-	White-Grey	White-Grey	White-Grey	White-Grey	White-Grey	White-Grey
Pair 6	-	-	-	-	-	Red-Blue	Red-Blue	Red-Blue	Red-Blue	Red-Blue
Pair 7	-	-	-	-	-	Red-Orange	Red-Orange	Red-Orange	Red-Orange	Red-Orange
Pair 8	-	-	-	-	-	Red-Green	Red-Green	Red-Green	Red-Green	Red-Green
Pair 9	-	-	-	-	-	Red-Brown	Red-Brown	Red-Brown	Red-Brown	Red-Brown
Pair 10	-	-	-	-	-	Red-Grey	Red-Grey	Red-Grey	Red-Grey	Red-Grey
Pair 11	-	-	-	-	-	-	Black-Blue	-	Black-Blue	Black-Blue
Pair 12	-	-	-	-	-	-	Black-Orange	-	Black-Orange	Black-Orange
Pair 13	-	-	-	-	-	-	Black-Green	-	Black-Green	Black-Green
Pair 14	-	-	-	-	-	-	Black-Brown	-	Black-Brown	Black-Brown
Pair 15	-	-	-	-	-	-	Black-Grey	-	Black-Grey	Black-Grey
Pair 16	-	-	-	-	-	-	Yellow-Blue	-	Yellow-Blue	Yellow-Blue
Pair 17	-	-	-	-	-	-	Yellow-Orange	-	Yellow-Orange	Yellow-Orange
Pair 18	-	-	-	-	-	-	Yellow-Green	-	Yellow-Green	Yellow-Green
Pair 19	-	-	-	-	-	-	Yellow-Brown	-	Yellow-Brown	Yellow-Brown
Pair 20	-	-	-	-	-	-	Yellow-Grey	-	Yellow-Grey	Yellow-Grey

No. of Unit	1X1P	1X2P	1X3P	1X4P	1X5P	1X10P	1X20P	5X10P	5X20P	
Colour of Unit Identification Binder		0.4 mm dia. & 0.5 mm dia.								
Unit 1	-	-	-	-	-	-	-	Blue	Blue	
Unit 2	-	-	-	-	-	-	-	Orange	Orange	
Unit 3	-	-	-	-	-	-	-	Green	Green	
Unit 4	-	-	-	-	-	-	-	Brown	Brown	
Unit 5	-	-	-	-	-	-	-	Grey	Grey	
PVC Jacket (0.4 mm dia. & 0.5 mm dia.)		FRPVC compound with high oxygen index								
Approx. Outer Diameter	0.4 mm dia. 0.5 mm dia.	2.40 2.75	3.10 3.50	3.50 4.00	3.90 4.70	4.30 5.50	6.20 8.20	8.40 10.50	12.30 15.20	16.80 20.40
Packing Length (mtrs)	0.4 mm dia. & 0.5 mm dia.	90	90	90	90	90	90	90	500	500

Electrical Parameters	0.4 mm dia	0.5 mm dia
Conductor Resistance (max.) ohms/km at 20°C	143.0	92.20
Unit of Mutual Capacitance : (Max.) nF/km	50	50
Insulation Resistance in Air (min.) M-ohms/km	10,000	10,000
Capacitance Unbalance Pair to Pair (max.) pF/km	250	250

# Finolex Cables Limited

AN IS/ISO 9001 CERTIFIED COMPANY

26-27, Mumbai-Pune Road, Pimpri, Pune - 411018, India.  
Tel: 020-27506200 | Visit us at: www.finolex.com  
Email: sales@finolex.com  
CIN: L31300MH1967PLC016531

FOR TECHNICAL LITERATURE PLEASE CONTACT OUR BRANCH OFFICES: Ahmedabad : Tel: 079-26584637 / 26575639 | Bengaluru : Tel: 9845278680 | Bhubaneswar : Tel: 0674-2971188, 2971922 | Chennai : Tel: 044-28231514 / 28284141 | Chandigarh : Tel: 9316064670 | Cochin : Tel: 9880088155 | Coimbatore : Tel: 0422-2330997 | Dharwad : Tel: 9880088155 | Goa : Tel: 0832-2782003 / 2782065 | Gurgaon : Tel: 9896763770 | Guwahati : Tel: 9435324398 | Indore : Tel: 7314911723 | Jaipur : Tel: 9929111411 | Kolkata : Tel: 0522-4035031 | Lucknow : Tel: 9560299393 | Mumbai : Tel: 022 - 22820062 | New Delhi : Tel: 9870170171 | Patna : Tel: 9934107999 | Pune : Tel: 020 - 27506200 | Raipur : Tel: 7008336581 | Ranchi : Tel: 8101383841 | Secunderabad : Tel: 040 - 27811161 | Uttarakhand : Tel: 9760045003 | Vadodara : Tel: 9879555568 | Vijayawada : Tel: 9848043967

 /finolexcables  /finolexcables  /finolex.cables

ALL INFORMATION GIVEN HEREIN IS IN GOOD FAITH. FINOLEX SHALL NOT BE LIABLE FOR ANY DAMAGES ARISING OUT OF INCORRECT USE OR INTERPRETATION. In order to derive maximum benefit and utilisation of our products, we advise that these products are stored, installed and commissioned as per the norms prevailing in the place of installation. When decommissioned, these should be disposed using appropriate methods/process specified in respective state / location of use so as not to affect the environment adversely. While every effort has been taken to guarantee that all details and portrayals are correct, this leaflet should not be viewed as a definitive guide or as a proposal of sales for a specific product. Due to variable factors in the production process, shades of the actual product might fluctuate marginally from those portrayed. Model numbers and particulars are for reference purposes only. May subject to change without prior notice.

# FLAME RETARDANT

## Flame Retardant (FR) PVC Insulated Industrial Cables



High Insulation  
Resistance



Anti-Termite  
Rodent Repellent



RoHS  
Compliant



REACH  
Compliant



### XCEEDS EXPECTATIONS

# Finolex Cables Limited

Started in 1958, Finolex Cables Limited is India's largest and leading electrical and telecommunication cables manufacturer. Finolex Cables has always believed in enhancing capabilities and augmenting the product basket. In last few years, besides the cables business the company has forayed into new segments and added new products under the Finolex brand. The company offers Total Electrical Solutions with products like Electrical Wires, 3 Core Flat Cables, Communication Cables, Telecommunication Cables, Flexible Cables, Auto Cables, Conduits, Room Heaters, LED Lights, Switches, Switchgears, Fans, Irons and Water Heaters. Finolex Cables Limited has four manufacturing facilities viz. at Pimpri (Pune), Urse (near Pune), Verna (Goa) and Roorkee (Uttarakhand).

The company is known for their unmatched quality and safety standard which has made it amongst the most reliable brands of the country. Over the six-decade long journey, Finolex Cables has cemented its reputation as an innovative leader and quality manufacturer by continuously upgrading technology, modernizing manufacturing facilities and maintaining the highest standards in quality and service.

## Flame Retardant (FR) PVC Insulated Industrial Cables

One of the core products of Finolex Cables, Flame retardant (FR) PVC insulated industrial cables, offer added safety. This is also RoHS and REACH Compliant making it environment friendly. Additionally, it's Anti Termite and Rodent Repellent.

Each wire is manufactured using 99.96% pure, electrolytic grade, bright annealed bare copper with more than 100% conductivity for conductor. This copper is manufactured at the company's state-of-the-art plant in Goa. Highest purity and conductivity of copper ensures greater saving of electrical energy, thus helping reduce electricity bills. The conductor is made of multiple strands of finely drawn copper wires thereby offering greater flexibility which makes these wires ideal for conduit wiring.

The wires are insulated with FR (Flame Retardant) PVC compound, specially formulated and manufactured in-house. This PVC compound has FR properties of high oxygen and temperature index. These properties help in restricting the spread of fire even at very high temperatures. This special compound also offers high insulation resistance and dielectric strength. Insulation is applied over the conductor by the process of dual extrusion using state-of-the-art extrusion lines. The outer skin determines the colour identification while the inner layer is pure insulation which provides extra protection. All wires are subjected to high voltage spark testing to make sure that there are no weak spots in the insulation.

These ISI marked wires meet the requirements of IS 694 : 2010 with latest amendments with improved fire performance for category FR. This means extra protection against electrical shocks, short circuits and fires.

Buy only from authorised Finolex outlets to be assured of total quality. If doubt arises about the authenticity of the purchase, please write to the company at the address given below. Send a copy of the cash memo, coil number and a metre-length sample of the cable to enable genuineness tests to be carried out in the laboratory.

These wires are manufactured in our state-of-the-art manufacturing plants at Urse (Near Pune), Verna (Goa) & Roorkee (Uttarakhand).

The brand Finolex, company logo, size of wire, voltage grade FR Type, ISI mark, licence no. are printed at regular intervals on the wire to help in easy identification as shown below.

FR PROPERTIES		
Test	Test Method Specified	Specification Values
Critical Oxygen Index	IS:10810 Part 58	Oxygen Index Minimum 29%
Temperature Index	IS:10810 Part 64	Temperature Index 250° C Minimum at 21% Oxygen

Also meet requirements of Flammability Test as per IS 694:2010



### FLAME RETARDANT (FR) PVC INSULATED INDUSTRIAL CABLES SINGLE CORE, UNSHEATHED CABLES IN VOLTAGE GRADE 1100V

Nominal area of copper conductor	Thickness of insulation (Nominal)	Approximate overall diameter of wire	Current carrying capacity # 2 wires, single phase		Resistance (Max.) per km. @20° C
			In conduit / Trunking	Unenclosed - clipped directly to a surface or on cable tray	
Sq. mm	mm	mm	Amps	Amps	Ohm
0.75	0.6	2.3	6	7	26.0
1.0	0.7	2.6	11	12	19.5
1.5	0.7	2.9	13	16	13.3
2.5	0.8	3.6	18	22	7.98
4.0	0.8	4.0	24	29	4.95
6.0	0.8	4.5	31	37	3.30

Standard Colours: Black, Red, Blue, Yellow and Green (for earthing). Supplied in 90 M length  
# As per IS 3961 (Part V) - 1968 BIS license Nos. CM/L 7306463 CM/L 7525273 & CM/L 8944096



26-27, Mumbai-Pune Road, Pimpri, Pune - 411018, India.  
Tel: 020-27506200 | Visit us at: www.finolex.com  
Email: sales@finolex.com  
CIN: L31300MH1967PLC016531

FOR TECHNICAL LITERATURE PLEASE CONTACT OUR BRANCH OFFICES: Ahmedabad : Tel: 079-26584637 / 26575639 | Bengaluru : Tel: 9845278680 | Bhubaneswar : Tel: 0674-2971188, 2971922 | Chennai : Tel: 044-28231514/28284141 | Chandigarh : Tel: 9316064670 | Cochin : Tel: 9880088155 | Coimbatore : Tel: 0422-2330997 | Dharwad : Tel: 9880088155 | Goa : Tel: 0832-2782003 / 2782065 | Gurgaon : Tel: 9896763770 | Guwahati : Tel: 9435324398 | Indore : Tel: 7314911723 | Jaipur : Tel: 9929111411 | Kolkata : Tel: 0522-4035031 | Lucknow : Tel: 9560299393 | Mumbai : Tel: 022 - 22820062 | New Delhi : Tel: 9870170171 | Patna : Tel: 9934107999 | Pune : Tel: 020 - 27506200 | Raipur : Tel: 7008336581 | Ranchi : Tel: 8101383841 | Secunderabad : Tel: 040 - 27811161 | Uttarakhand : Tel: 9760045003 | Vadodara : Tel: 9879555568 | Vijayawada : Tel: 9848043967

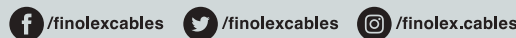

ALL INFORMATION GIVEN HEREIN IS IN GOOD FAITH. FINOLEX SHALL NOT BE LIABLE FOR ANY DAMAGES ARISING OUT OF INCORRECT USE OR INTERPRETATION. In order to derive maximum benefit and utilisation of our products, we advise that these products are stored, installed and commissioned as per the norms prevailing in the place of installation. When decommissioned, these should be disposed using appropriate methods/process specified in respective state / location of use so as not to affect the environment adversely. While every effort has been taken to guarantee that all details and portrayals are correct, this leaflet should not be viewed as a definitive guide or as a proposal of sales for a specific product. Due to variable factors in the production process, shades of the actual product might fluctuate marginally from those portrayed. Model numbers and particulars are for reference purposes only. May subject to change without prior notice.