



F A N S

TRULY
FANTASTIC

CATALOGUE
2025



A large, stylized, white outline version of the word "Fybrós" is centered horizontally across the middle of the image. The letters are bold and have a modern, slightly italicized feel. Above the letter "o" is a graphic consisting of three white, curved lines that resemble a flame or a stylized wave, identical to the one in the top right logo.



A LEGACY OF TRUST AND INNOVATION

For over five decades, our commitment to excellence and innovation has remained at the forefront of our mission. With each passing year, Fybros has continued to push the boundaries of comfort and style, earning the trust and loyalty of countless customers. As we unveil our latest offering, we invite you to embark on a journey that will witness the future of cooling solutions.

Whether you are seeking a fan that whispers serenity into your bedroom, a fan that stands as a statement piece in your living room, or a high-performance fan for your workspace, we have you covered. From sleek and contemporary designs that seamlessly blend with modern interiors to timeless classics that exude elegance, our collection is meticulously crafted to elevate the aesthetics of any space while providing optimal cooling efficiency.

With every fan in our collection, you will experience the essence of our legacy built on trust, quality, and relentless innovation. Our fans are not just appliances; they embody comfort and peace of mind.

Bladeless Fans

01₈₋₁₁



GLIDE

Ceiling Fans

02₁₂₋₄₁



Super Premium Fans

F-WAVE
GREZIA
BRISA
ELLA
SILENT WAVE
URUS*
AERIST ART
AERIS PRO
AERIS
LOFT
STELLA

03₄₂₋₅₉



Premium Fans

CASA PLUS
CASA BLDC
OLYMPIA
AERO
SOLIS

04₆₀₋₆₅



Decorative Fans

F-FLOW PRO
AIR-1 PRO

05₆₈₋₈₃



Standard Fans

AIR-1
FALCON SS
F-FLOW
YALE
NIMO
VELO
MENOR

Portable Fans

06₈₄₋₁₃₃



Table Fans

VAYU
GUSH
NOOK
NOOK PLUS

Wall Fans

VAYU
GUSH
NOOK
NOOK PLUS
MANGNUM

Pedestal Fans

VAYU
GUSH
NOOK
NOOK PLUS
F-SPIN
F-SPIN 3
MAGNUM
THUNDER
THUNDER-3

Personal Fans

LUNA 2X2
SILO
GALE
TRI AIR
HANDY GUST

Exhaust Fans

07₁₃₄₋₁₅₀



Axial Fans

ZEST
ENOR
LUSH

Ventilation Fans

VENTFLO
VENTI AIR

Metal Exhaust Fans

EXFLO PLUS
EXFLO

Contents

Next Gen Comfort

Presenting a breakthrough in air cooling technology, this advanced device seamlessly integrates bladeless fan technology with air purification, setting the stage for a new era in home comfort. With its sleek design and user-friendly controls, it not only transforms the cooling experience but also represents the next frontier in creating healthier indoor environments by effectively eliminating airborne particles and allergens.



Bladeless Fans

GLIDE

Bladeless Fan with Air Purifier

The future of cooling and air purification in one sleek and innovative device -Glide Bladeless Fan. This cutting-edge fan combines state-of-the-art technology with unparalleled convenience, making it a must-have for modern homes. it's the future of comfort and air quality in one.

PRODUCT CODE	FF 1001
SWEEP (mm)	Bladeless
POWER (W)	35
WIND SPEED (m/s)	5.8

Attractive and Sleek Design

Blade less Operation

Air Purifier with H13 HEPA & Carbon Filter

80 Degree Auto Oscillation & 15 Degree manual Tilting at both Sides

Remote Controlled



HEPA &
CARBON FILTER



ADJUSTABLE
ANGLE



90° LEFT / RIGHT
OSCILLATION



BLADELESS



AIR PURIFICATION



PORTABLE



GLIDE Bladeless Fan with Air Purifier

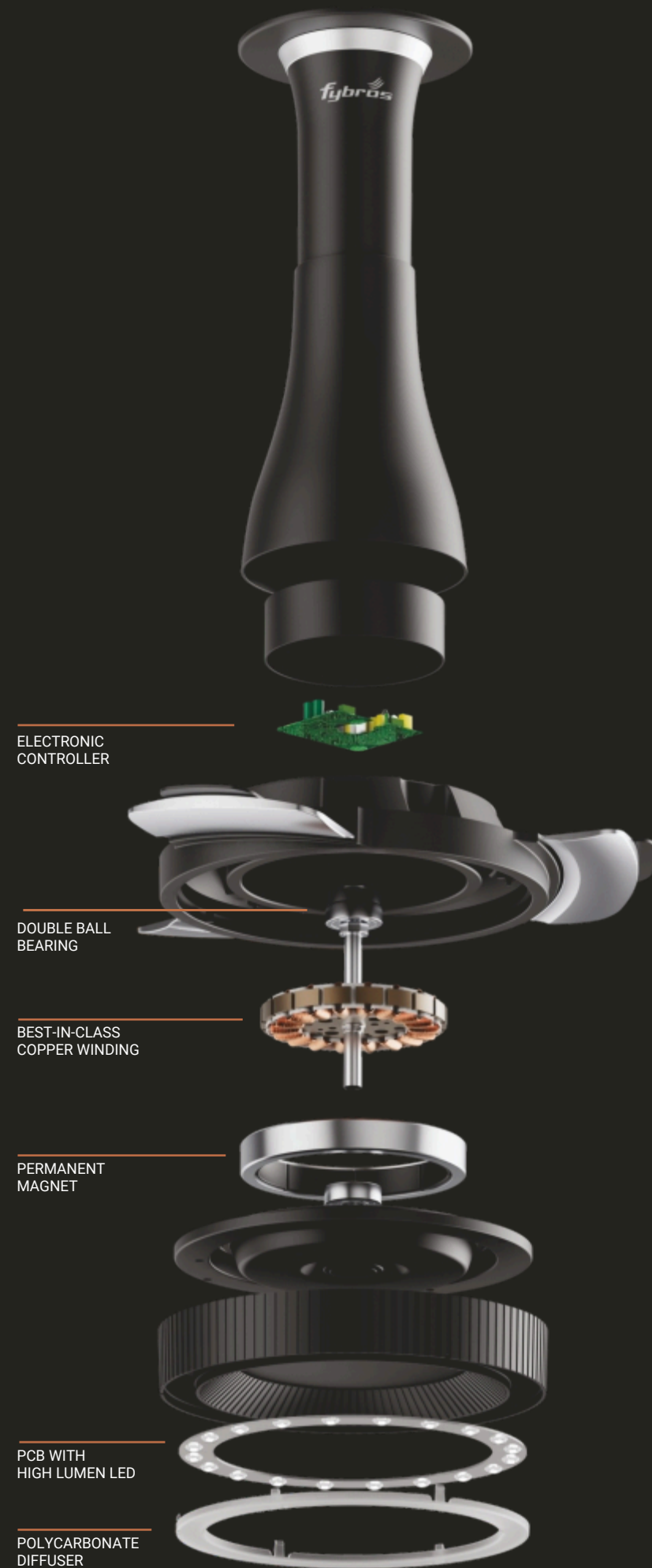

REVOLUTIONIZING Comfort and Efficiency

In an ever-evolving world, where innovation drives progress, we proudly introduce our range of BLDC (Brushless Direct Current) fans—a testament to our commitment to embracing cutting-edge technology in the pursuit of unparalleled comfort and energy efficiency.

Unlike traditional fans, BLDC fans come equipped with brushless motors, offering a host of advantages. They are not only quieter but also remarkably energy-efficient, setting new standards for performance and sustainability. Representing a significant leap forward in energy efficiency, these fans consume up to 50% less power than conventional fans. This efficiency translates not only into lower electricity bills, allowing you to recover the cost of the fan in 2 years, but also into a reduced carbon footprint, contributing to a greener planet. With Fybrós BLDC fans, we empower you to make a conscious choice for both your comfort and the environment.

As you explore our BLDC fan collection, you'll discover a range of styles and designs that cater to your unique preferences while delivering exceptional energy efficiency. Choose BLDC fans and experience the perfect blend of comfort, savings, and sustainability.



F-WAVE

Glowing Sophistication,
Elegance in each Spin.

Ceiling Fans



Immerse yourself in the luxurious ambiance of the F-Wave Ceiling Fan. Whether you seek a tranquil ambiance or vibrant illumination, it is designed to meet your aesthetic preferences. With adjustable luminous intensities, it allows you to tailor the lighting to suit your mood, creating an atmosphere of unparalleled elegance.



F-WAVE Ceiling Fan

The future of cooling and air purification in one sleek and innovative device -Glide Bladeless Fan. This cutting-edge fan combines state-of-the-art technology with unparalleled convenience, making it a must-have for modern homes. It's the future of comfort and air quality in one.

PRODUCT CODE	FF 1101
SWEEP (mm)	1200 35
POWER (W)	350 220
SPEED (RPM)	
AIR DELIVERY (cmm)	

- Enriches the decor
- Attractive ring light
- Aerodynamically designed blades
- Remote Controlled
- Highly Efficient BLDC Motor
- 3 LED Colour Variants

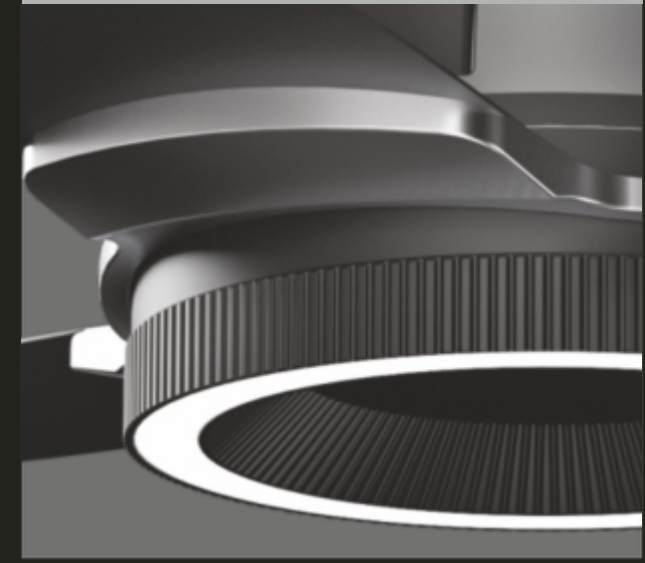

Registered Design no. 399805-001



Matt Black



Satin White



American Walnut



ANTI-DUST



HIGH TORQUE



ENERGY EFFICIENT



TRI COLOUR LED LIGHTS



HIGH AIR DELIVERY



F-WAVE Ceiling Fan



GREZIA Ceiling Fan

The Grezia Ceiling Fan - a delightful fusion of timeless elegance and modern allure, designed to enhance your living space with a one-of-a-kind charm. Available in two alluring colours, this marvel of craftsmanship can be effortlessly controlled with a convenient remote, ensuring a seamless and enjoyable experience. Elevate your home decor to new heights with the mesmerizing presence of the Grezia Ceiling Fan

PRODUCT CODE	FF 1108
SWEEP (mm)	1320 40
POWER (W)	240 230
SPEED (RPM)	
AIR DELIVERY (cmm)	

- Aerodynamic designed blades for superior air delivery.
- High gloss premium finish with PU paints.
- 100% rust free blades made from high grade glass filled ABS.
- Heavy motor design for long lasting life.
- Aerofoil design for noise less operation.



Graphite Black



Glacier White



GREZIA Ceiling Fan



BRISA Ceiling Fan

Immerse yourself in the captivating allure of the Brisa Ceiling fan, where timeless elegance seamlessly melds with modern design elements. The fan's exquisitely crafted form is complemented by an adaptable under-light, casting its radiant glow in a trinity of captivating hues while offering a spectrum of luminous intensities

PRODUCT CODE	FF 1109
SWEEP (mm)	1230 38
POWER (W)	200 230
SPEED (RPM)	
AIR DELIVERY (cmm)	

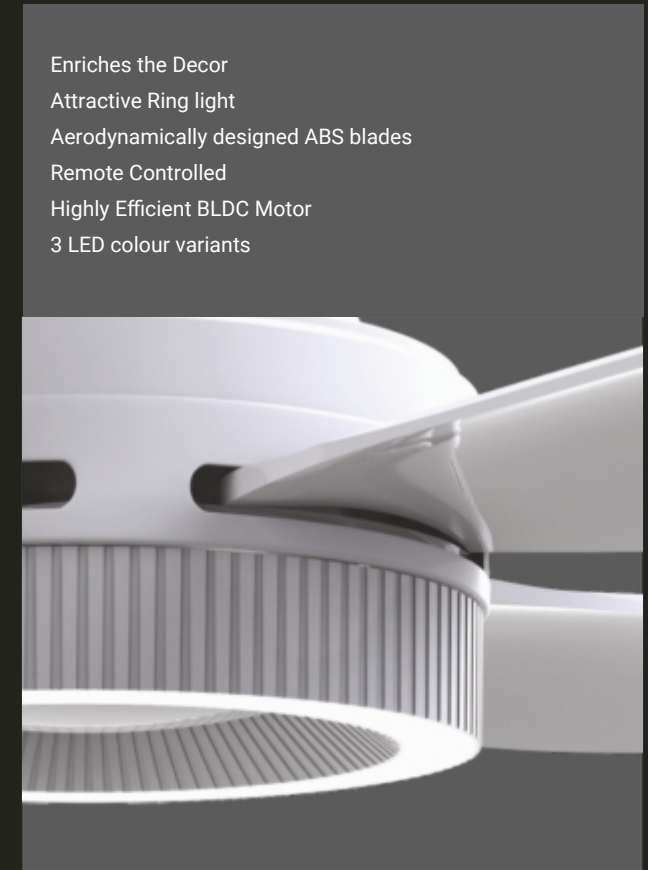

Enriches the Decor
 Attractive Ring light
 Aerodynamically designed ABS blades
 Remote Controlled
 Highly Efficient BLDC Motor
 3 LED colour variants

 NOISE LESS FAN

 HIGH TORQUE

 TRI COLOUR LED LIGHTS

 ENERGY EFFICIENT

 HIGH AIR DELIVERY



Charcoal Grey



Everest White



BRISA Ceiling Fan



CM/L-8100181907

ELLA Ceiling Fan

The Ella Ceiling Fan a delightful fusion of timeless elegance and modern allure, designed to enhance your living space with a one-of-a-kind charm. Available in two alluring colours, this marvel of craftsmanship can be effortlessly controlled with a convenient remote, ensuring a seamless and enjoyable experience. Elevate your home decor to new heights with the mesmerizing presence of the Ella Ceiling Fan.

PRODUCT CODE	FF 1102
SWEEP (mm)	1230 38
POWER (W)	200 230
SPEED (RPM)	
AIR DELIVERY (cmm)	

- Enhances the Aura
- Aerodynamic designed blades
- Resin blades for Higher Air Thrust
- Noiseless Operation
- Highly Efficient BLDC Motor
- Remote Controlled



American Walnut



Satin White

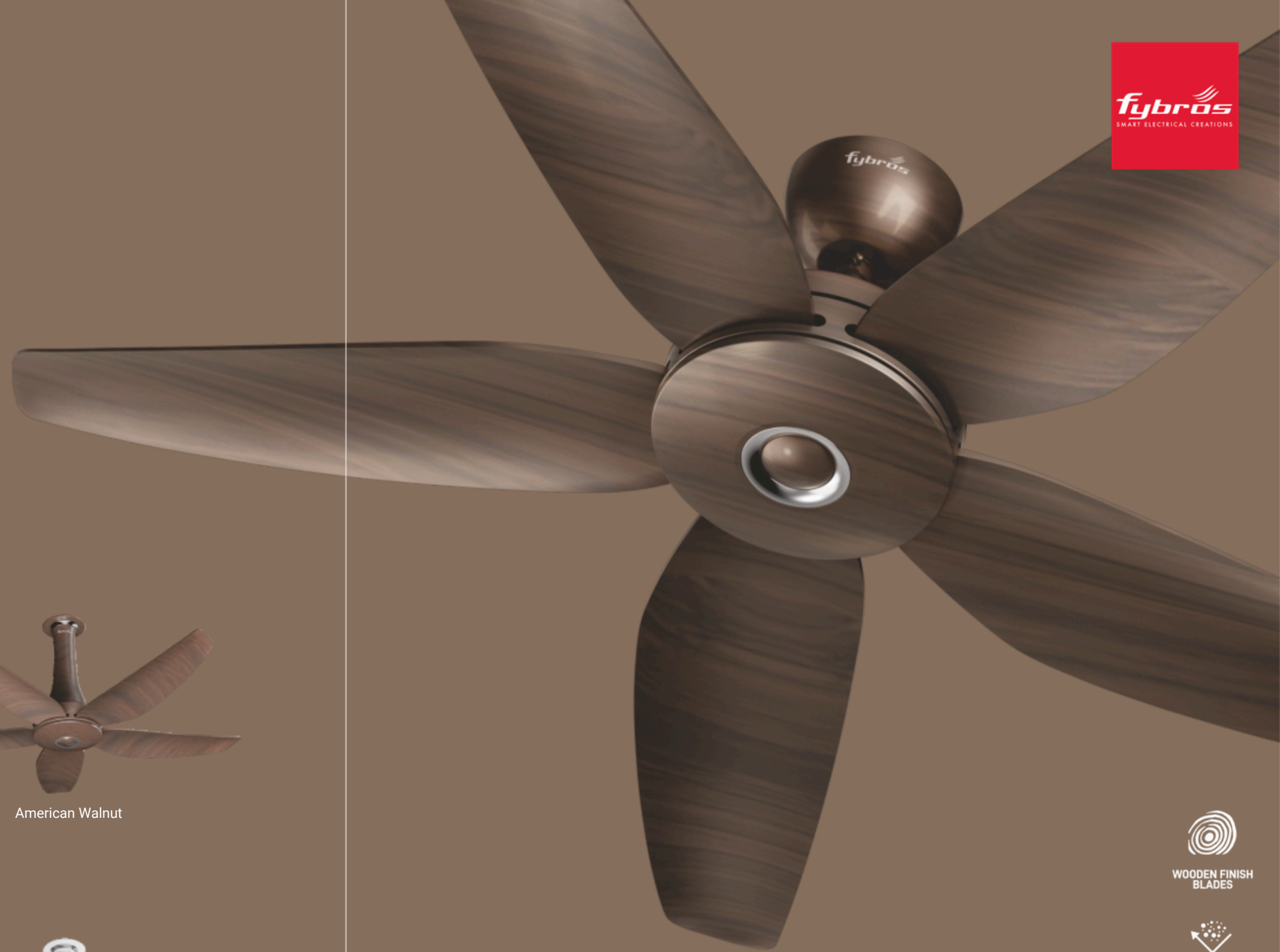

ELLA Ceiling Fan



SILENT WAVE

Immerse yourself in the captivating allure of the Brisa

Ceiling fan, where timeless elegance seamlessly melds with modern design elements. The fan's exquisitely crafted form is complemented by an adaptable under-light, casting its radiant glow in a trinity of captivating hues while offering a spectrum of luminous intensities

PRODUCT CODE	FF 1110
SWEEP (mm)	1200 57
POWER (W)	300 235
SPEED (RPM)	
AIR DELIVERY (cmm)	

Aerodynamic designed blades for superior air delivery.
 High gloss premium finish with PU paints.
 100% rust free blades made from high grade glass filled ABS.
 Heavy motor design for long lasting life.
 Aerofoil design for noise less operation.

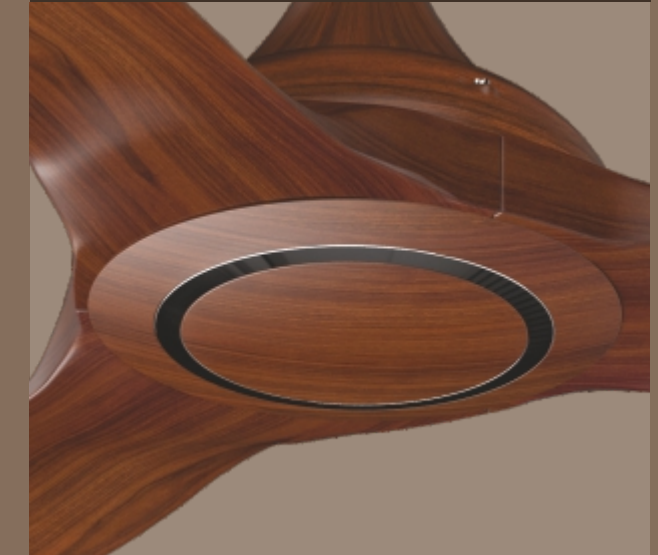

Caramel Brown



Walnut Wood



Sparkle White



SILENT WAVE Ceiling Fan





URUS* ceiling Fan

The Urus* fan combines classical and contemporary aesthetics, elevating your decor with a unique touch. It comprises six blades and an adjustable under-light that illuminates in three colours and various brightness levels. It comes in three antique finishes and can be conveniently controlled via remote.

PRODUCT CODE	FF 1103
SWEEP (mm)	1200 40
POWER (W)	330 220
SPEED (RPM)	
AIR DELIVERY (cmm)	

- Silent Operations
- Highly Efficient BLDC Motor
- Remote Controlled
- 3 LED Colour variants
- Electroplated Coating on Motor
- Uplifts the Ambience with wooden finish blades
- 6 Blades for uniform Air Thrust

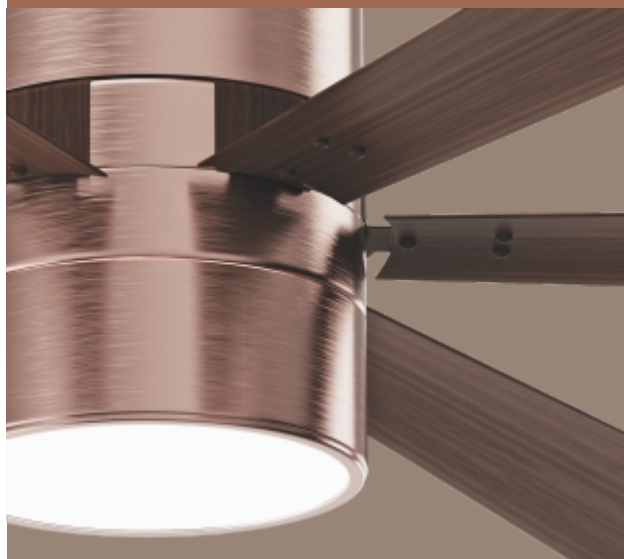

Antique Silver
Dark Wood



Antique Brass
Dark Wood



Antique Copper
Rose Wood





AERIS PRO

Effortless Elegance
with Exceptional Finesse

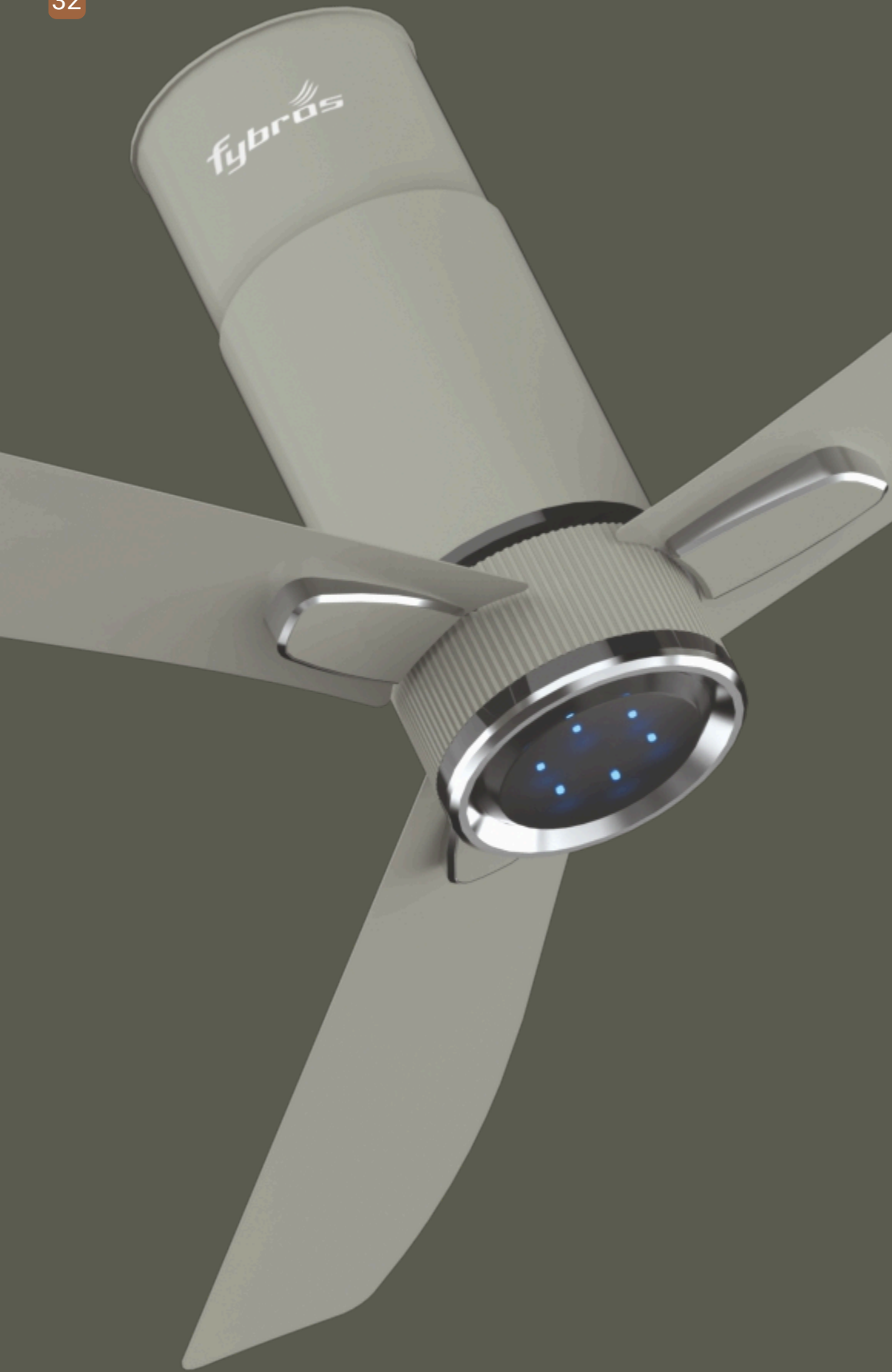

AERIS ART

AERIS ART Ceiling fan designed by master craftsmen to provide high air thrust at low power consumption and noiseless operation. The high gloss PU paint finish with aesthetically designed Aerodynamic Unique Blade ensure maximum comfort and lasting life.

PRODUCT CODE	FF 1111
SWEEP (mm)	1200 32
POWER (W)	350 220
SPEED (RPM)	
AIR DELIVERY (cmm)	



Glacier White



Gravity Grey



Stealth Black



- Uplifts the Ambience
- Unique Blade Design
- Attractive Sleek Motor
- Speed LED Indicator
- Highly Efficient BLDC Motor
- Remote Controlled

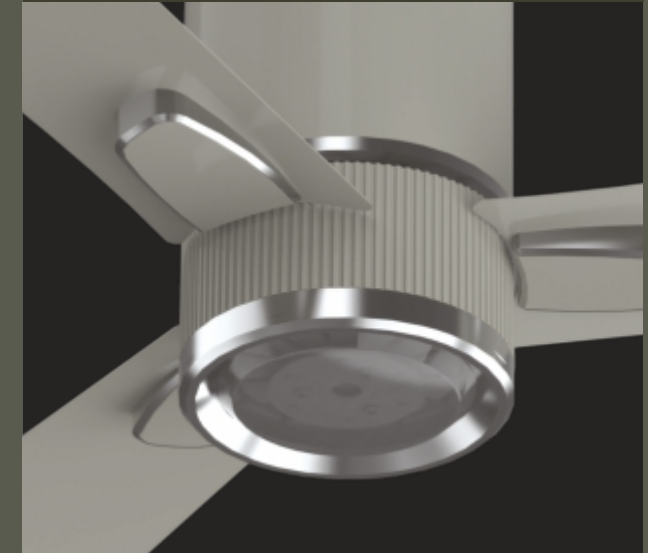

AERIS ART Ceiling Fan



AERIS PRO

The incredibly efficient Aeris PRO fan is the perfect cooling solution for your household during the summer. It comes with a responsive motor to ensure quiet performance and ribbed blades that ensure improved air circulation. It not only enhances the visual charm of your home but also guarantees prolonged, uninterrupted operation.

PRODUCT CODE	FF 1104
SWEEP (mm)	1200 32
POWER (W)	350 220
SPEED (RPM)	
AIR DELIVERY (cmm)	

Uplifts the Ambience
 Unique Blade Design
 Attractive Sleek Motor
 Speed LED Indicator Highly
 Efficient BLDC Motor
 Remote Controlled



Oakwood Black

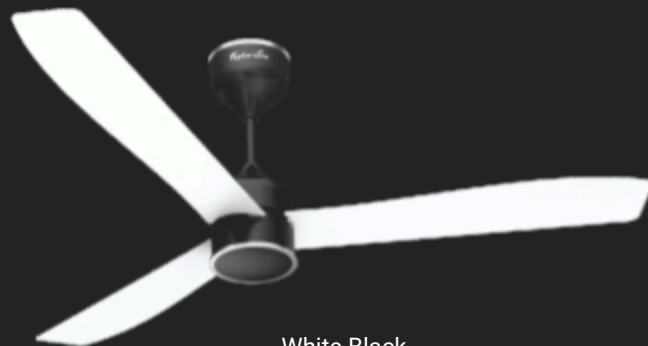

White Black



SLIM & TRENDY

BEST-IN-CLASS COPPER

DOUBLE BALL BEARING

HIGH TORQUE

HIGH AIR DELIVERY



AERIS PRO Ceiling Fan



AERIS Ceiling Fan

The AERIS Fan transcends mere functionality; its timeless design, embellished with metallic-finished blades, imparts an element of elegance to your home. Experience the seamless fusion of performance and aesthetics, offered in two distinct colour options. This makes it the perfect companion for creating a cool and stylish living space.

PRODUCT CODE	FF 1105
SWEEP (mm)	1200 32
POWER (W)	350 220
SPEED (RPM)	
AIR DELIVERY (cmm)	

- Unique Blade Design
- Attractive Sleek Motor
- Speed LED Indicator
- Highly Efficient BLDC Motor
- Remote Controlled

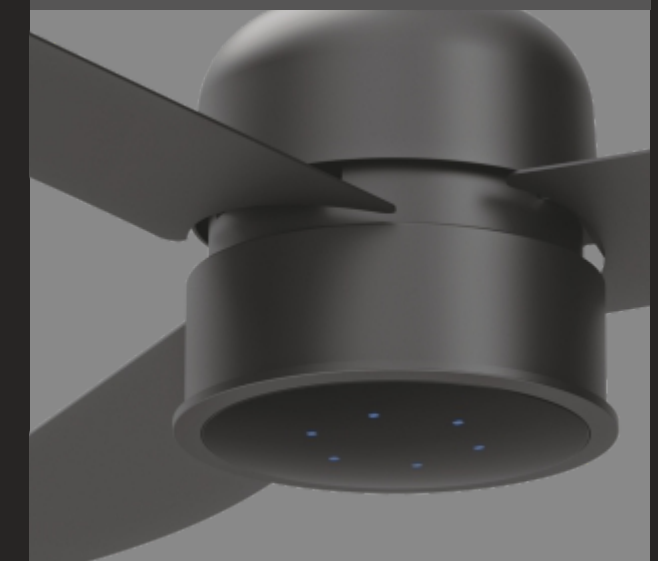

AERIS Ceiling Fan



LOFT Ceiling Fan

Introducing the Loft fan - a true blend of style and functionality. Elevate your surroundings with this remarkable fan that seamlessly combines modern design with advanced features. The Loft fan is not just a cooling solution; it's a statement piece that enhances the ambiance of any space. The Wooden Finish Blades add a touch of elegance, creating a harmonious blend of aesthetics and utility. Enjoy a refreshing ambiance with low maintenance, thanks to its Dust Resistant build.

PRODUCT CODE	FF 1106
SWEEP (mm)	800 50
POWER (W)	350 160
SPEED (RPM)	
AIR DELIVERY (cmm)	

Electroplated Coating on Motor
Uplifts the ambience
6 blades for Uniform Air Thrust



Antique Silver - Dark Wood



Antique Copper - Rose Wood



LOFT Ceiling Fan



IS-374:2019



CM/L-8100181907

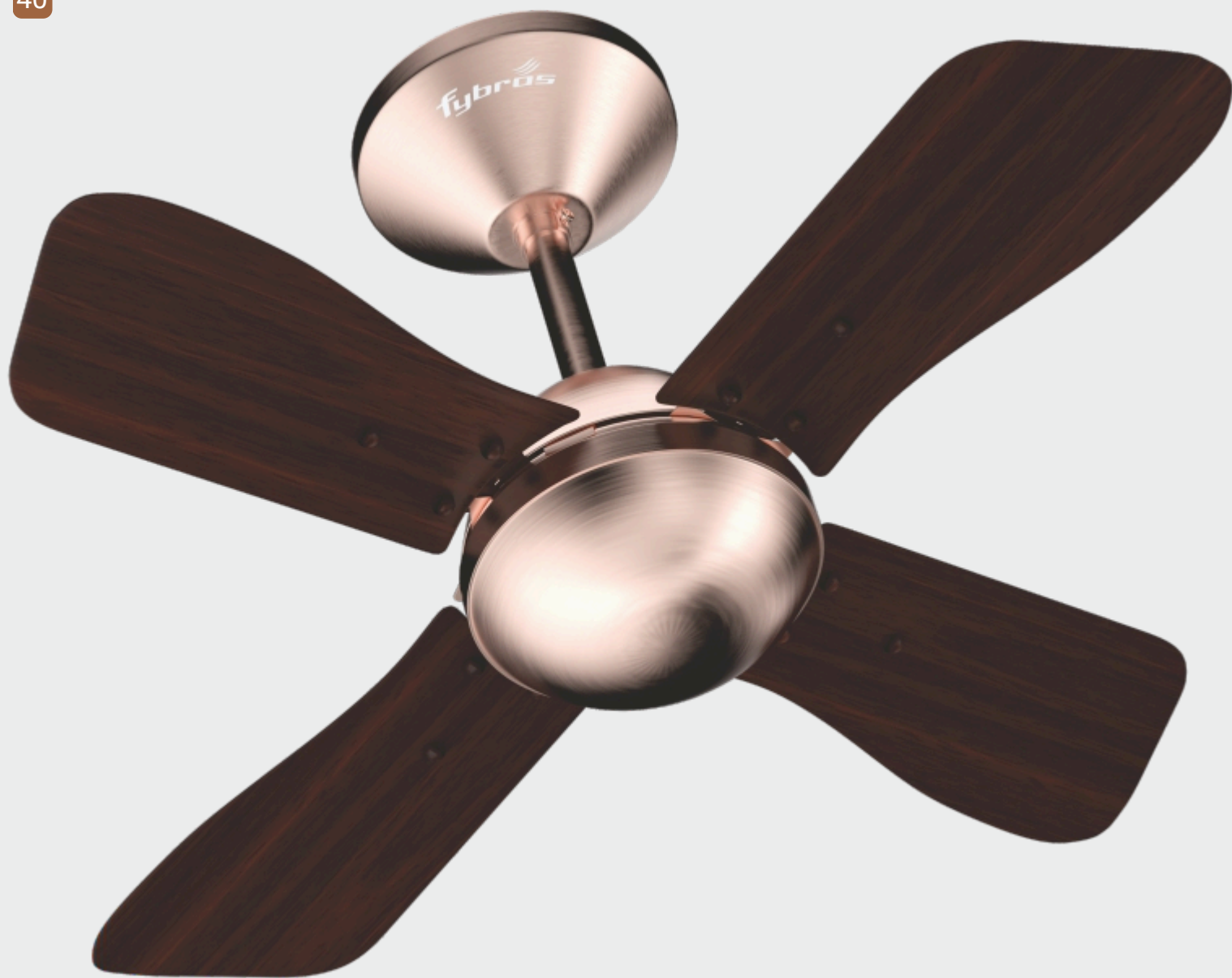

STELLA Ceiling Fan

Discover the Stella fan-a testament to the notion that life's finest offerings often arrive in modest sizes. With its one-of-a-kind design featuring four blades, Stella boasts an electroplated body and offers a diverse range of wood finish options. Housing an impressively robust motor beneath its unassuming exterior, the fan operates with remarkable silence while swiftly infusing the surrounding area with a refreshing coolness.

PRODUCT CODE	FF 1107
SWEEP (mm)	600 60
POWER (W)	850 140
SPEED (RPM)	
AIR DELIVERY (cmm)	



Antique Silver
Dark Wood



Antique Copper
Rose Wood



Electroplated Coating on Motor
Enhances the decor
Comes with 4 blades



STELLA Ceiling Fan



Style Meets Efficiency

Elevate your living spaces with our exclusive range of decorative fans, where functionality meets artistry. At Fybro, we believe a fan is more than just a cooling device; it's an integral part of your interior design. Our range of decorative fans seamlessly blends form and function.



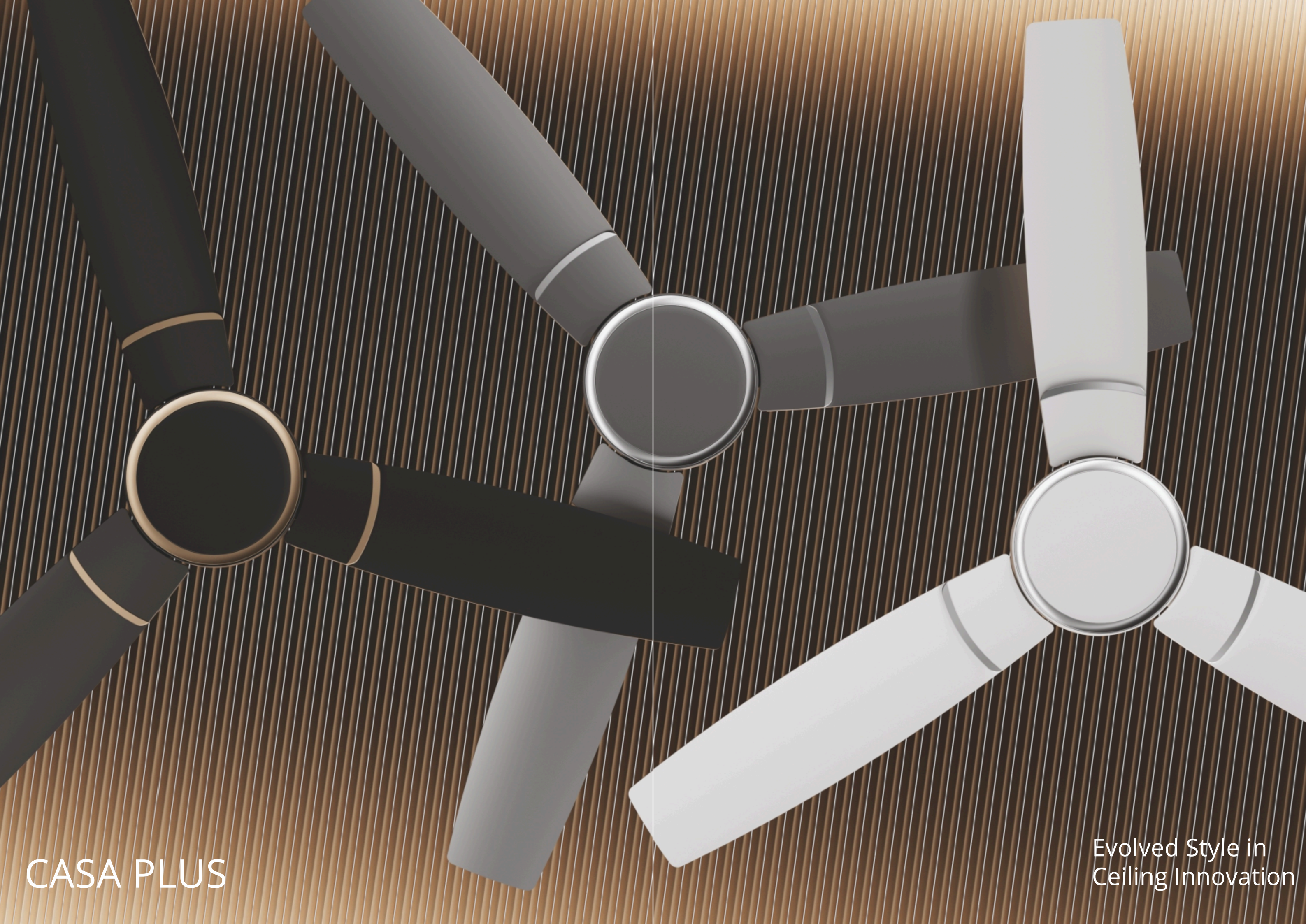

CASA PLUS

Evolved Style in
Ceiling Innovation



CASA PLUS Ceiling Fan

Presenting the CASA PLUS premium fan-a chic solution to beat the scorching summer heat. Carefully crafted with top-notch components, this aesthetically pleasing fan provides exceptional airflow while operating in blissful silence. With four captivating colours to choose from, the CASA PLUS fan combines functionality with style

PRODUCT CODE	FF 2107
SWEEP (mm)	900 44 1200
POWER (W)	450 140 52
SPEED (RPM)	350
AIR DELIVERY (cmm)	225

- Stylish finishes to complement any decor
- Unique Blade Design
- Optimum Airflow
- Energy Efficient
- OPLV Technology-
- Optimum Performance at Low Voltage



Matt Range



Midnight Grey

Skyline Blue



Charcoal Black

Matt White

Glossy Range



Topaz Gold

Angel White



Dove Grey

Wood Range



Oakwood

- BEST-IN-CLASS COPPER
- ENDURING COAT
- 360° AIR CIRCULATION
- ANTI-DUST

CASA PLUS Ceiling Fan

Registered Design no. 399806-001





CASA BLDC Ceiling Fan

Discover the CASA BLDC Fan, a harmonious fusion of style and innovation. With its advanced BLDC technology, this fan offers exceptional energy efficiency and whisper-quiet operation, ensuring a tranquil and cool atmosphere. Elevate your summer comfort with CASA BLDC, where cutting-edge technology harmonizes effortlessly with captivating aesthetics.

PRODUCT CODE	FF 2102
SWEEP (mm)	1200 35
POWER (W)	350 225
SPEED (RPM)	
AIR DELIVERY (cmm)	

- Noiseless & Seamless Operation
- Timeless design
- Remote Controlled
- 60% Energy Efficiency than Traditional Fans
- Inverter Friendly
- Optimum Airflow



Midnight Grey



Baker Brown



Angel White



Dove Grey

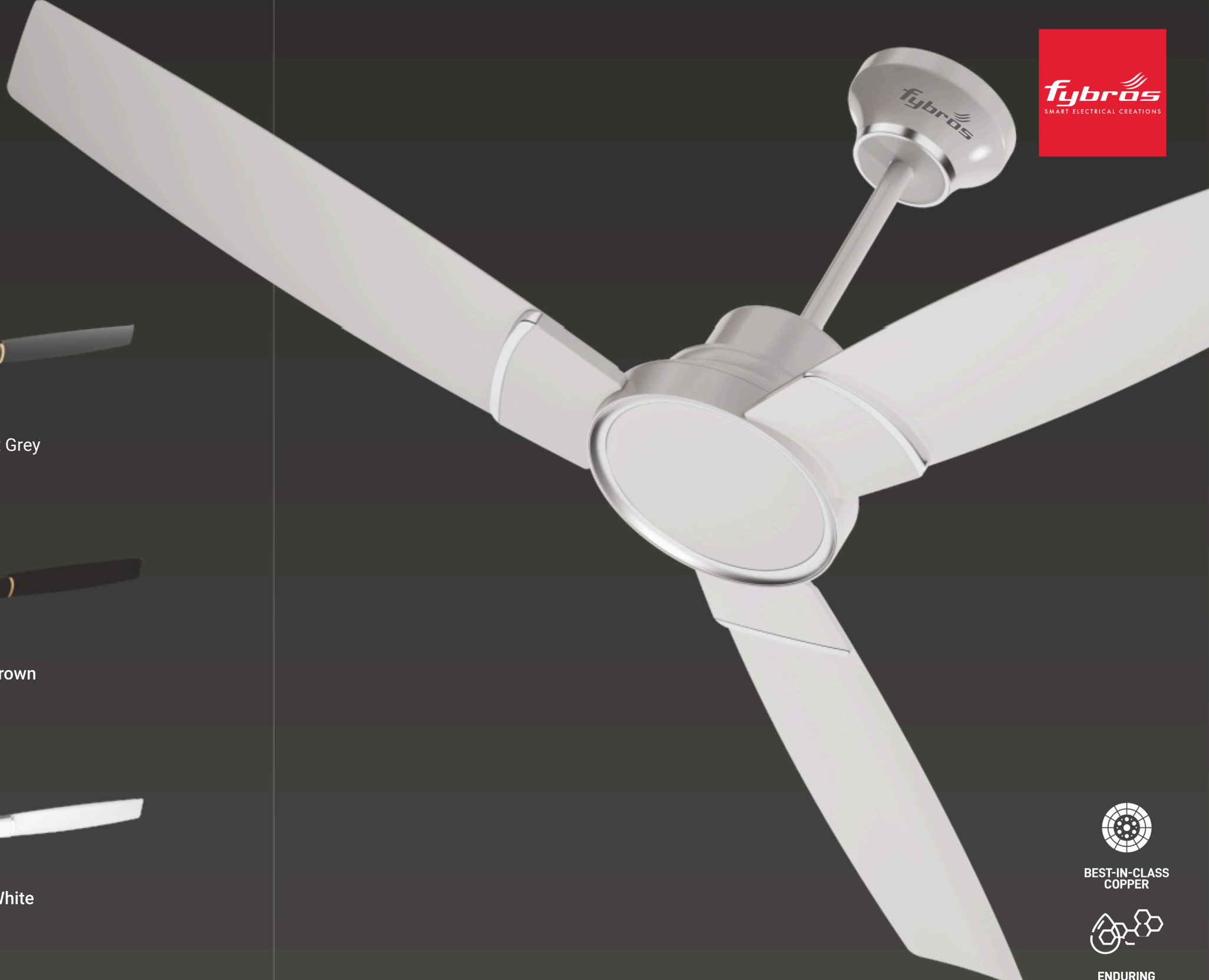

BEST-IN-CLASS COPPER



ENDURING COAT



360° AIR CIRCULATION



ANTI-DUST



* 2 YEARS FOR ELECTRIC CONTROLLER
3 YEARS FOR MOTOR



IS-374:2019



CM/L-8300138211

CASA BLDC Ceiling Fan

Registered Design no. 399806-001

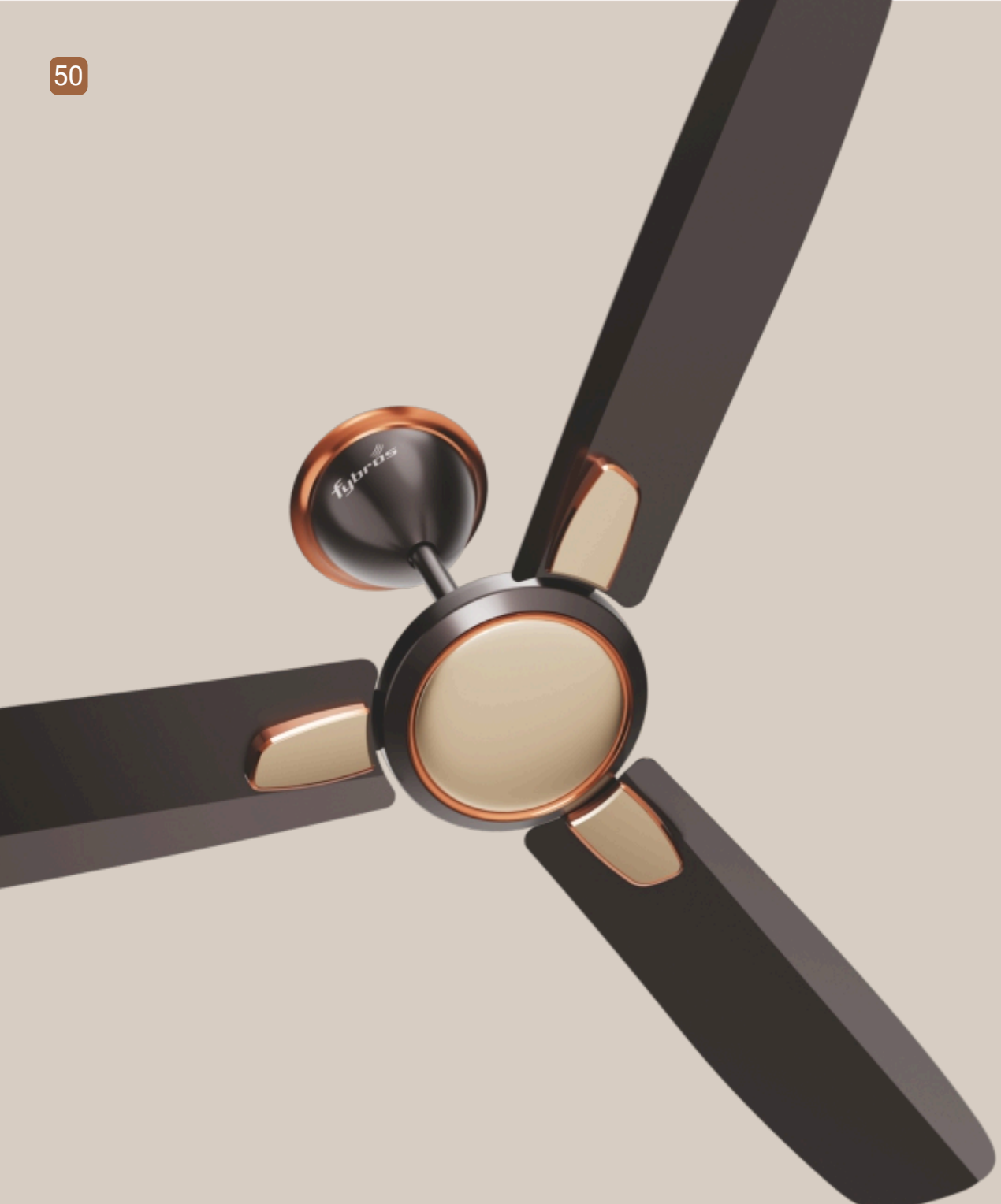

OLYMPIA Ceiling Fan

Olympia Fan is crafted to complement modern and contemporary lifestyles, which effortlessly stands out as a prominent fixture in Indian households. Its gracefully curved embellishments create a captivating visual contrast with its body colour, resulting in an enchanting spectacle. To further emphasise its double tone paint finish, the Olympia features an anti-dust capability, ensuring that its pristine finish remains intact for an extended period of time. Beyond its captivating beauty, this fan excels in efficiency, promptly delivering refreshing and effective cooling whenever needed.

PRODUCT CODE	FF 2103
SWEEP (mm)	900 45 1200
POWER (W)	450 140 53
SPEED (RPM)	350
AIR DELIVERY (cmm)	220



Radiant Blue Silver



Topaz Gold Chocolate



Chocolate Gold



Sparkle White

- Enchanting Bicolour Design
- Wide Angle blades
- Dust Resistant
- Energy Efficient
- OPLV Technology
- Optimum Performance at Low Voltage



DOUBLE BALL BEARING

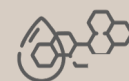

ENDURING COAT



360° AIR CIRCULATION



BEST-IN-CLASS COPPER

OLYMPIA Ceiling Fan

Registered Design no. 399808-001



IS-374:2019



CM/L-6300103079



AERO Ceiling Fan

The Aero Fan epitomises a unique and captivating aesthetic, establishing itself as the ultimate choice for chic, contemporary homes and offices. Its broader blades, meticulously crafted with optimal aerodynamics, guarantees increased airflow even at lower speed. Moreover, its premium paint finish, reinforced motor, and high-quality copper windings combine to provide an extended lifespan while exuding an exquisite elegance.

PRODUCT CODE	FF 2104
SWEEP (mm)	900 45 1200
POWER (W)	450 140 53
SPEED (RPM)	350
AIR DELIVERY (cmm)	220

- Premium Metallic Coating
- Wide angle blades
- Highly efficient performance
- Optimum Airflow
- OPLV Technology-
- Optimum Performance at Low Voltage

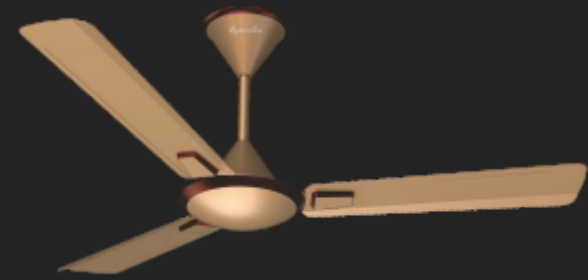

Imperial Gold



Sparkle Brown



Sparkle White



Coffee Brown



AERO Ceiling Fan

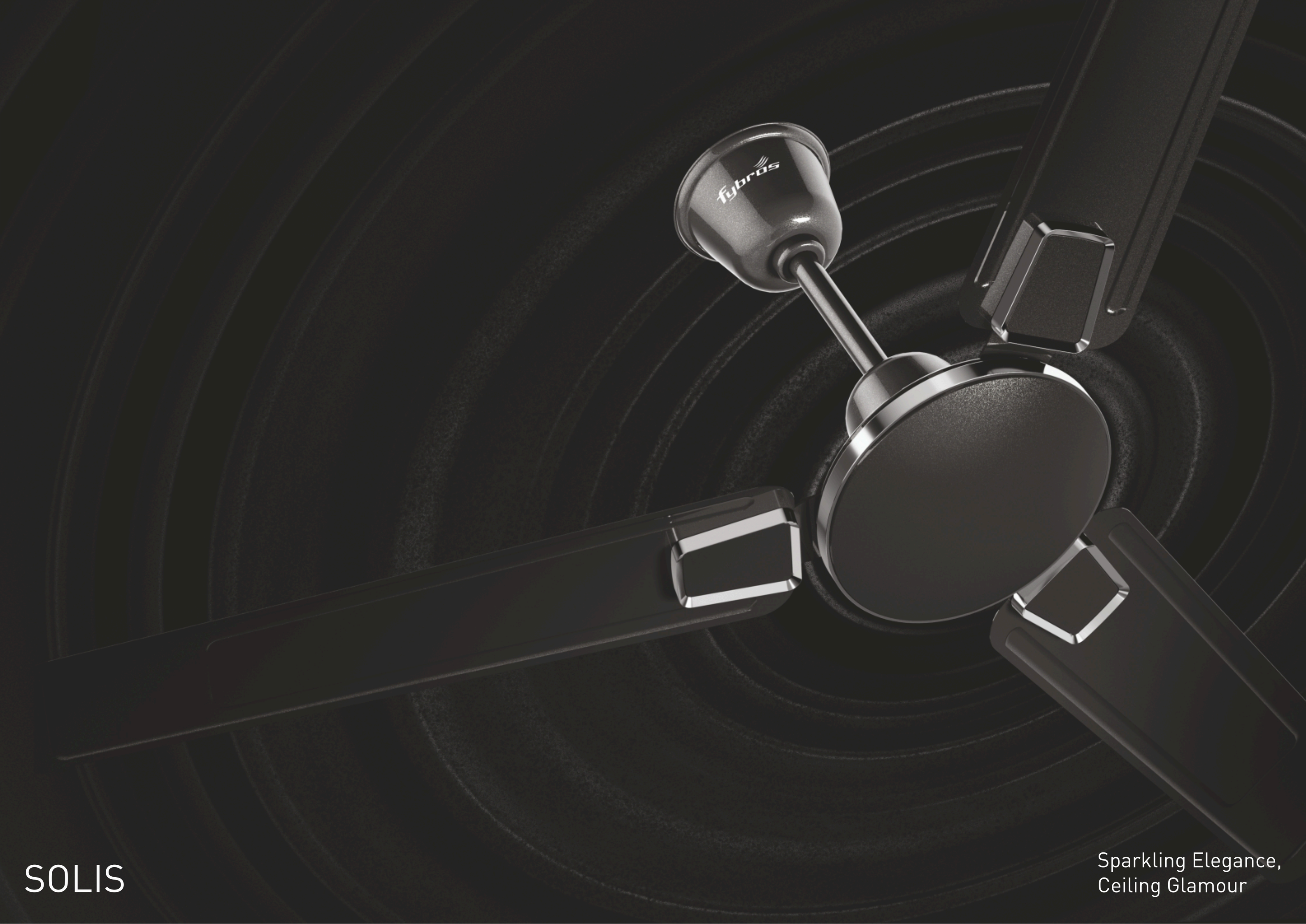

SOLIS

Sparkling Elegance,
Ceiling Glamour



SOLIS Ceiling Fan

The mesmerising Solis ornamental ceiling fan, ready to sweep you off your feet with their unrivalled performance. Harnessing a strong motor and cutting-edge aerodynamic blades, these fans generate a broader, cone-shaped breeze that effortlessly reaches every nook and cranny of your space. Engineered to operate flawlessly even under low voltage conditions, the Solis stands as a durable and resilient fan, promising years of consistent performance.

PRODUCT CODE	FF 2106
SWEEP (mm)	900 45 1200
POWER (W)	450 140 52
SPEED (RPM)	380
AIR DELIVERY (cmm)	210

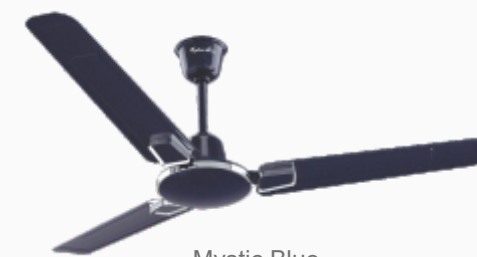

Mystic Blue



Tangy Brown



Granite Grey



Pearl White



Meticulously designed
 Highly efficient performance
 Aerodynamically designed Blades
 Durable Powder Coating
 CRC Hi-Perm Steel Lamination for longer life



SOLIS Ceiling Fan

Registered Design no. 399809-001



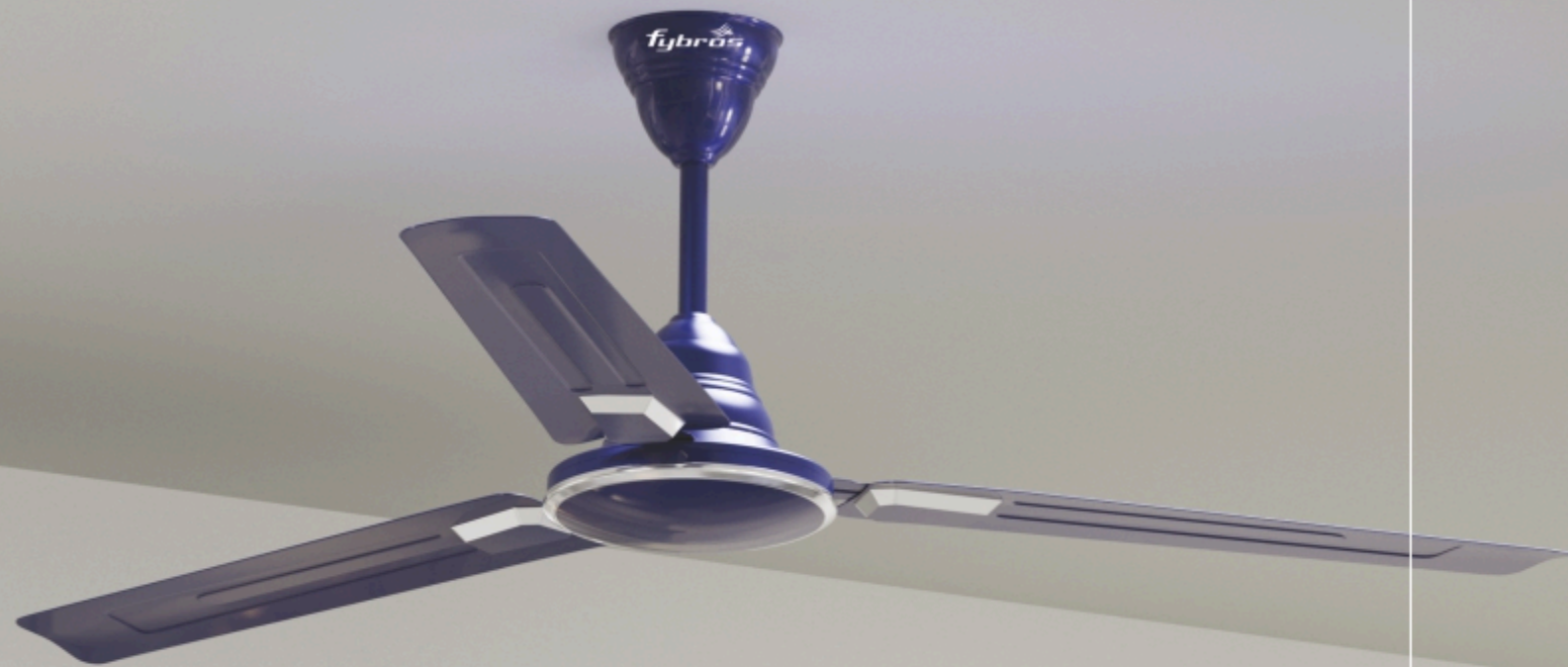

Stay Cool and Stylish in Comfort

Crafted with an exceptional design, our ceiling fans come in various styles, finishes, colours and sizes to suit your interior decor. While these fans are aesthetically pleasing, they also deliver efficient performance, thanks to powerful, energy-efficient motors. Whisper-quiet operation and convenient features like Remote Controls make them a delight to use.

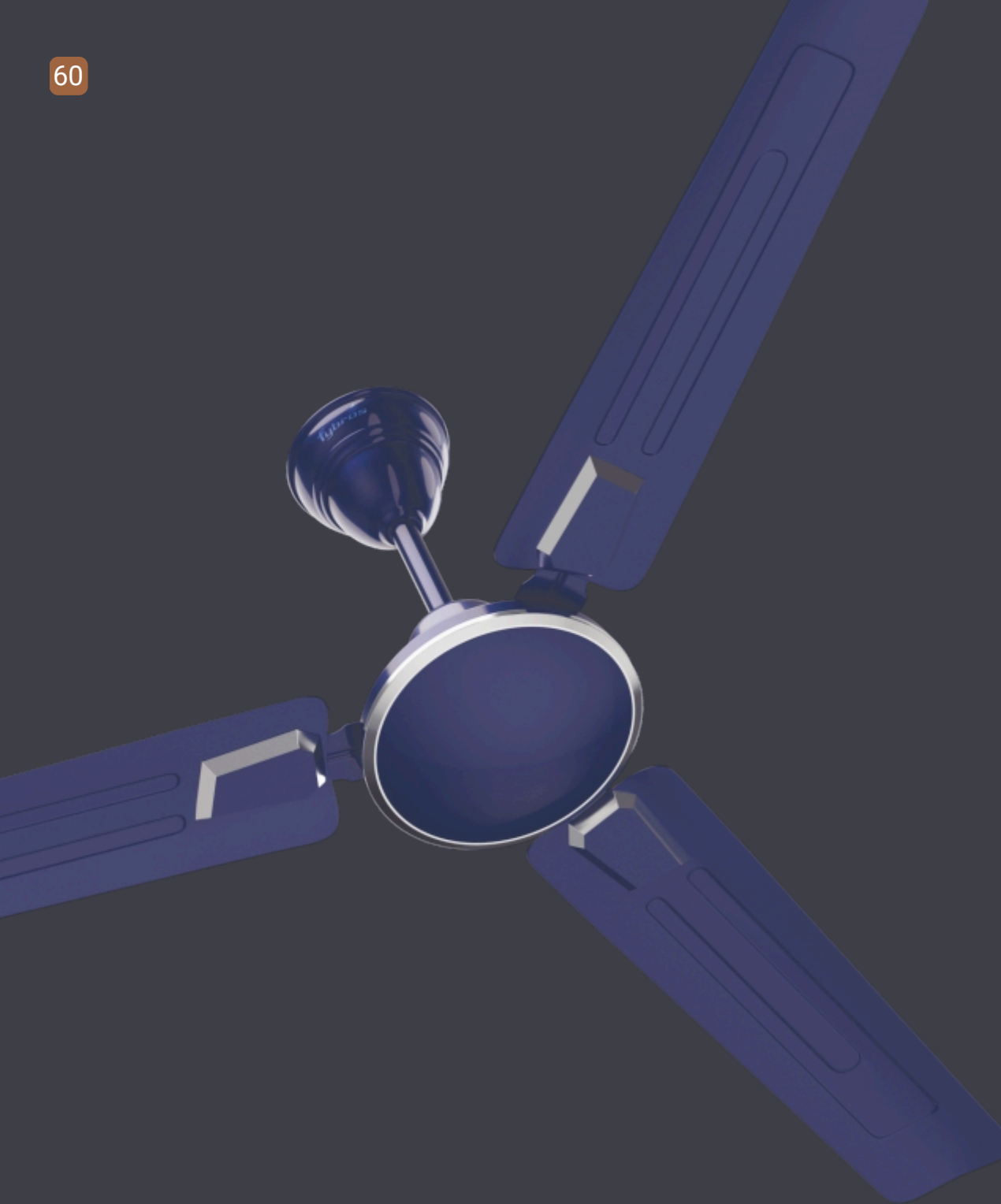

F-FLOW PRO Ceiling Fan

Experience the F Flow Pro Fan - a blend of durability and elegance. With its lasting finish, enjoy efficient performance and refreshing airflow. Its sleek design complements any decor, while aerodynamic blades and CRC Hi-Perm Steel Lamination ensure longevity.

PRODUCT CODE	FF 3101
SWEEP (mm)	900 45 1200
POWER (W)	450 140 52
SPEED (RPM)	390
AIR DELIVERY (cmm)	210

- Striking design suitable for any decor
- Highly efficient performance
- Aerodynamically designed Blades
- Durable Finish
- CRC Hi-Perm Steel Lamination for longer Life

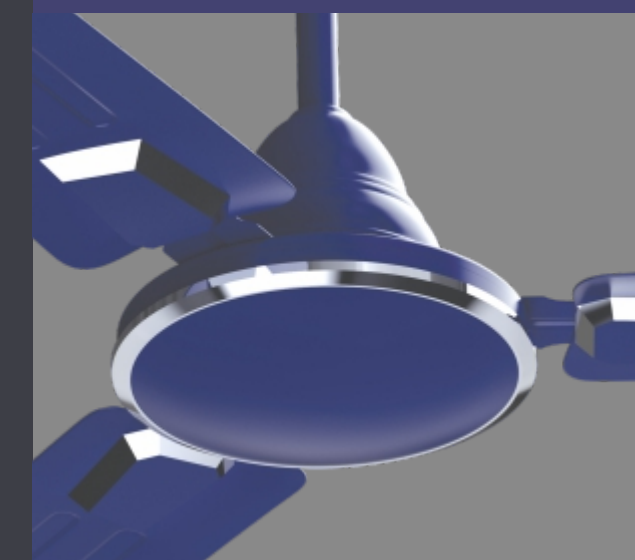

Rich Brown



Matt Brown



Smoke Brown



Bianco



Blue



F-FLOW PRO Ceiling Fan





AIR-1 PRO Ceiling Fan

The AIR-1 Pro fan exemplifies optimal air circulation within your living space through its powerful motor and feather-light blades. It exudes an air of refinement, seamlessly blending style with functionality, effortlessly producing a refreshing, high-velocity breeze. It offers an exquisite charm, further elevated by the inclusion of intricate metallic rings adorning the motor, adding a layer of elegance to any room.

PRODUCT CODE	FF 3102		
SWEEP (mm)	900	1200	1400
POWER (W)	45	52	60
SPEED (RPM)	450	400	290
AIR DELIVERY (cmm)	140	210	250



Rich Brown



Matt Brown



Smoke Brown



White



Ivory

Striking design suitable for any decor
 Highly efficient performance
 Aerodynamically designed Blades
 Durable Finish
 CRC Hi-Perm Steel Lamination for longer life



DOUBLE BALL BEARING



HIGH AIR DELIVERY



SUPER SPEED



BEST-IN-CLASS COPPER



IS-374:2019



CM/L-8300133706

AIR-1 PRO Ceiling Fan

Registered Design no. 399806-001

Discover Tranquillity in Every Rotation



Elevate your living spaces with our standard ceiling fans collection, meticulously designed to seamlessly blend functionality and aesthetics. Crafted with precision, our fans promise optimal air circulation, ensuring a refreshing breeze that caters to your comfort in every season. The advanced motor technology guarantees a whisper-quiet operation, transforming your space into a haven of calmness, free from disturbances.

Our ceiling fans go beyond mere performance, making a statement with their aesthetic appeal. Choose from a diverse range of contemporary and timeless designs to complement your unique style, adding a touch of sophistication to any room. Embrace both form and function as our fans not only enhance the visual appeal of your space but also contribute to a sustainable future with their energy-efficient design.

Personalization takes centre stage with our ceiling fans, allowing you to tailor your fan to match your preferences precisely. From a variety of finishes to blade designs and colour options, create a bespoke fan that seamlessly integrates with your interior decor. Invest in a living experience that transcends the ordinary, as our ceiling fans embody the perfect blend of style, and efficiency.



Discover the pinnacle of style & cooling

Committed to enhancing aesthetics and ambience, we've designed our fans to be stylish and environmentally conscious, using energy-efficient components that reduce power consumption. Our decorative fans infuse sophistication and comfort, adding an artistic touch to your living space. Choose style, comfort, and our decorative fans to upraise your space.

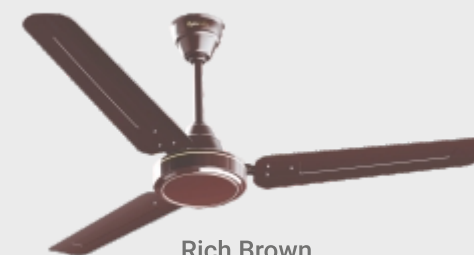

Rich Brown



Matt Brown

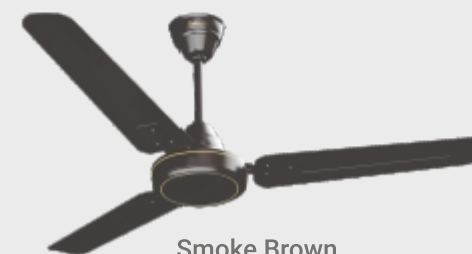

Smoke Brown



White



Ivory

AIR-1 Ceiling Fan

Immerse yourself in the pinnacle of speed and efficiency with the AIR-1 fan. Delivering a tranquil airflow at an astounding 450 RPM, this fan ensures an exceptional cooling experience. With its refined aesthetics and performance-oriented engineering, the AIR-1 fan stands as an indispensable addition to any Indian household. Whether it's a cosy living room, a productive workspace, or any other space, this fan is a must have for any area.

PRODUCT CODE	FF 4101
SWEEP (mm)	900 45 1200 1400
POWER (W)	450 140 52 60
SPEED (RPM)	400 290
AIR DELIVERY (cmm)	210 250

Sleek and refined aesthetics Highly efficient performance Optimum Airflow Durable Powder Coating CRC Hi-Perm Steel Lamination for longer life



Registered Design no. 399807-001

AIR-1 Ceiling Fan



FALCON SS Ceiling Fan

Discover the ultimate fusion of rapidity and effectiveness embodied in the Falcon SS Ceiling fan. Unleashing a serene breeze at 450 RPM, this fan guarantees an unparalleled and refreshing encounter with cooling prowess. Melding refined aesthetics and performance-driven craftsmanship, the Falcon SS fan emerges as an indispensable asset to elevate any Indian household

PRODUCT CODE	FF 4102
SWEEP (mm)	1200 52
POWER (W)	380 210
SPEED (RPM)	
AIR DELIVERY (cmm)	

Sleek and refined aesthetics
Highly efficient performance
Optimum Airflow
Durable Powder Coating
CRC Hi-Perm Steel Lamination for longer life



Rich Brown



Smoke Brown



Bianco



White



DOUBLE BALL BEARING



HIGH AIR DELIVERY



SUPER SPEED



BEST-IN-CLASS COPPER

FALCON SS Ceiling Fan





F-FLOW Ceiling Fan

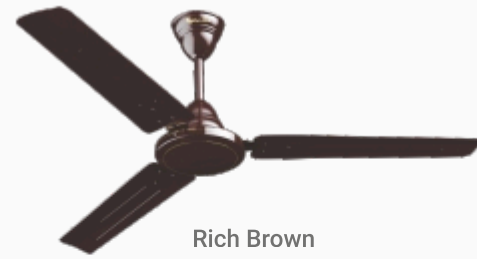

F-FLOW Ceiling Fan

Experience exceptional comfort and style with the F-Flow Fan, a perfect fusion of cutting-edge features and elegant design. Engineered for superior performance, this fan delivers highly efficient airflow that cools your space quickly and effectively.

PRODUCT CODE	FF 4103
SWEEP (mm)	900 45 1200
POWER (W)	450 140 52
SPEED (RPM)	390
AIR DELIVERY (cmm)	210

Sleek and refined aesthetics Highly efficient performance Optimum Airflow Durable Powder Coating CRC Hi-Perm Steel Lamination for longer life





YALE Ceiling Fan

Immerse yourself in the pinnacle of speed and efficiency with the YALE fan. Delivering a tranquil airflow this fan ensures an exceptional cooling experience. With its refined aesthetics and performance-oriented engineering, the YALE fan stands as an indispensable addition to any indian household. Whether It's a cosy living room,a productive workspace, or any other space, this fan is a must have for any area.

PRODUCT CODE	FF 4106
SWEEP (mm)	1200 52
POWER (W)	370 220
SPEED (RPM)	
AIR DELIVERY (cmm)	



Matt White



Smoke Brown



Matt Grey



Matt Blue

Attractive matt Finish to complement any decor.
 Wide angle aerodynamic blades.
 Optimum Airflow
 Noiseless and seamless operations.

OPLV Technology-
 Optimum Performance at Low Voltage

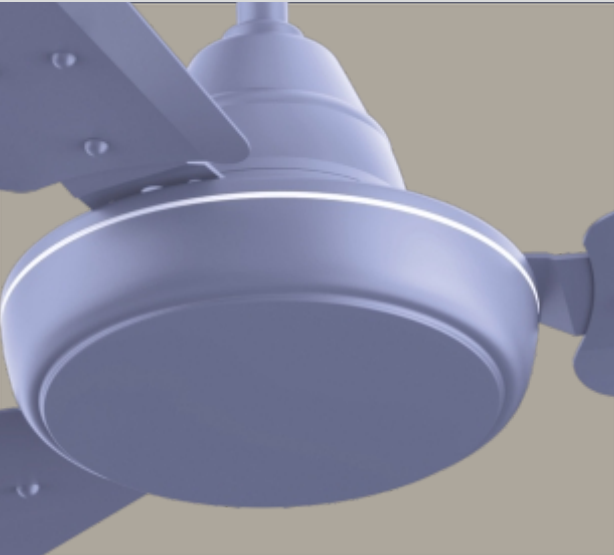

DOUBLE BALL BEARING



BEST-IN-CLASS COPPER



360° AIR CIRCULATION



HIGH AIR DELIVERY



HIGH SPEED



IS 374:2019



CM/L-9600070418

YALE Ceiling Fan



NIMO_{BLDC} Ceiling Fan



NIMO_{BLDC} Ceiling Fan

Embrace eco-consciousness with the revolutionary NIMO BLDC ceiling fan, a remarkable blend of technology and sustainability, capable of reducing energy usage by a staggering 60%. These cutting-edge fans require minimal upkeep, boasting of BLDC motor crafted from top-tier copper and exceptional bearings of international calibre, guaranteeing an extended lifespan. It operates without generating any heat, exhibiting flawless performance even under challenging conditions such as low voltage and power fluctuations.

PRODUCT CODE	FF 4107
SWEEP (mm)	1200 35
POWER (W)	350 220
SPEED (RPM)	
AIR DELIVERY (cmm)	

- Noiseless & Seamless Operation
- Timeless design
- Remote Controlled
- 60% Energy Efficiency than Traditional Fans
- Invertor Friendly
- Optimum Airflow





VELO Ceiling Fan

Embrace eco-consciousness with the revolutionary Velo ceiling fan, a remarkable blend of technology and sustainability, capable of reducing energy usage by a staggering 60%. These cutting-edge fans require minimal upkeep, boasting a motor crafted from top-tier copper and exceptional bearings of international calibre, guaranteeing an extended lifespan. It operates without generating any heat, exhibiting flawless performance even under challenging conditions such as low voltage and power fluctuations.

PRODUCT CODE	FF 4104
SWEEP (mm)	1200 30
POWER (W)	350 215
SPEED (RPM)	
AIR DELIVERY (cmm)	

- Noiseless & Seamless Operation
- Timeless design
- Remote Controlled
- 60% Energy Efficiency than Traditional Fans
- Inverter Friendly
- Optimum Airflow



Glossy Black



Rich White



Ivory



Royal Brown



Parameter	Power Consumption	Average Use of Fan Per Day (Hours)	Power Consumption (kWhr Units Per Day)	Electricity Bill Per Day @ ₹ 6.50/unit (Approx)	Electricity Bill Per Annum	Savings per Annum	Cost Saving
Conventional Fans	75W	16	1.2 kWh	₹ 7.80	₹ 2847/-	₹ ----	----
BLDC Fans	30W	16	0.48 kWh	₹ 3.12	₹ 1139/-	₹ 1708/-	60%



CM/L-8300133706



BEST-IN-CLASS COPPER



DOUBLE BALL BEARING



HIGH TORQUE



VELO Ceiling Fan



MENOR Ceiling Fan

Experience exceptional comfort and style with the Menor Fan, a perfect fusion of cutting-edge features and elegant design. Engineered for superior performance, this fan delivers highly efficient airflow that cools your space quickly and effectively.

PRODUCT CODE	FF 4105
SWEEP (mm)	600 65
POWER (W)	850 100
SPEED (RPM)	
AIR DELIVERY (cmm)	



Matt Brown



Rich Brown



Smoke Brown



Bianco



White

Sleek and refined aesthetics Highly efficient performance Optimum Airflow Durable Powder Coating CRC Hi-Perm Steel Lamination for longer life

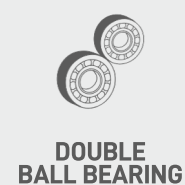

MENOR Ceiling Fan





VAYU Table Fan



Black Orange

VAYU Table Fan

VAYU, a top-notch table fan, packed with great features. Equipped with noise-reducing resin blades and corrosion-resistant, powder-coated metal guards, it offers a serene and dependable performance. Despite its robust motor and impressive speed capabilities, it offers a seamless and quiet oscillation experience.

PRODUCT CODE	FF 5101
SWEEP (mm)	400
POWER (W)	58
SPEED (RPM)	1330
AIR DELIVERY (cmm)	70

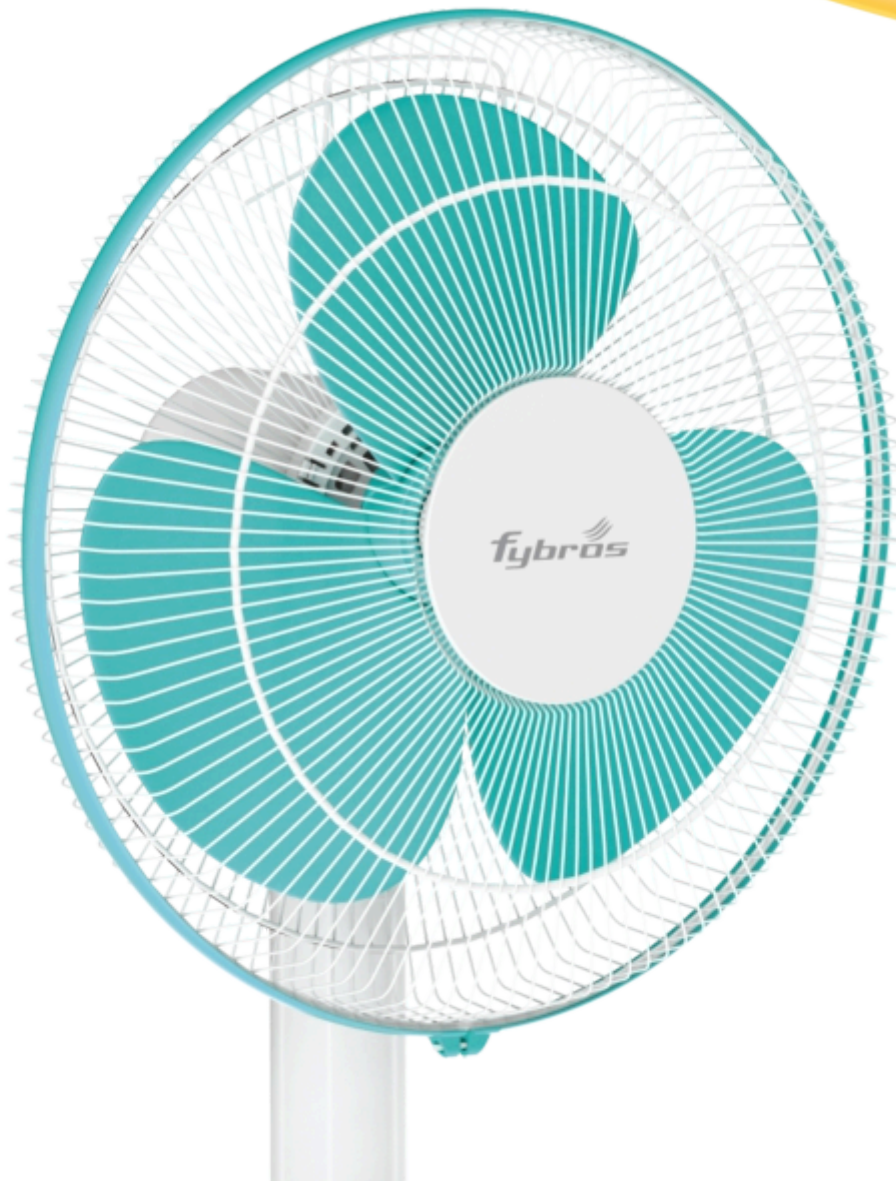

Fluorescent Blue



- Aerodynamically designed Resin Blades
- Jerk Free Oscillation
- Rust Resistant Powder Coated Guards
- Robust Motor
- Best-in-Class Copper



GUSH Table Fan

Gush Table Fan is equipped with advanced blades; which ensures efficient air circulation, while maintaining a whisper-quiet operation. Safety is paramount, with built-in thermal over load protector, providing peace of mind during prolonged use. Encased in powder-coated metal guards, this fan not only exudes durability but also complements your decor with its sleek design. Synchronous motor is provided to ensure smooth and uniform jerk free oscillation.

PRODUCT CODE	FF 5102
SWEEP (mm)	400 110
POWER (W)	2200 90
SPEED (RPM)	
AIR DELIVERY (cmm)	

- Aerodynamically designed Resin Blades
- Synchronous Motor
- Thermal Overload Protector
- Jerk Free Oscillation
- Rust Resistant Powder Coated Guards



Black Grey



White Grey

GUSH Table Fan

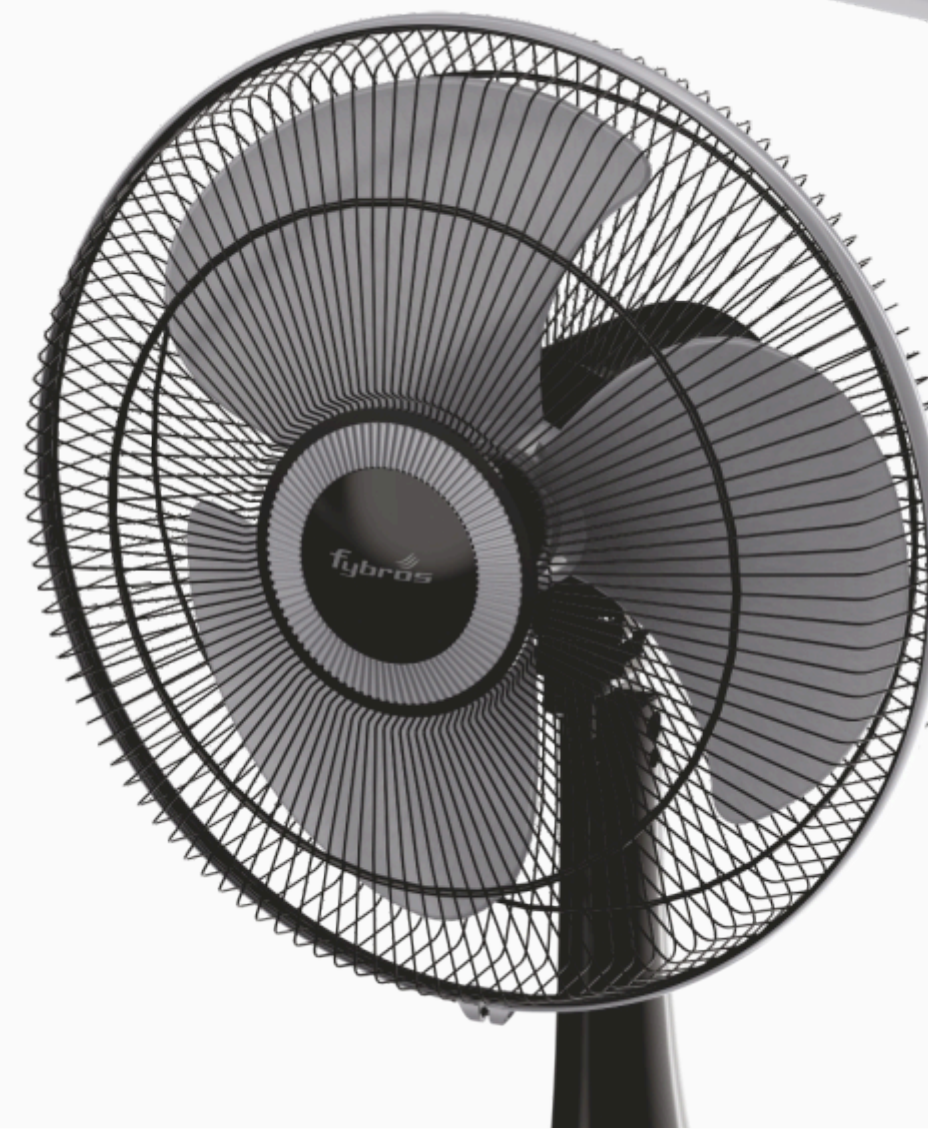

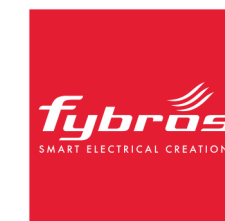

NOOK Table Fan

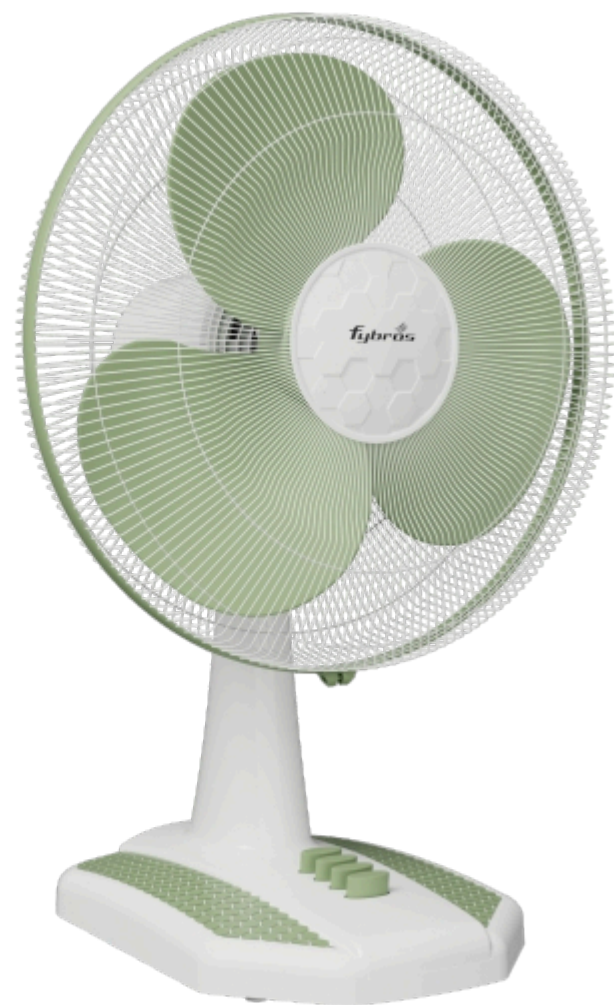

White Pistachio

NOOK Table Fan

NOOK, a top-notch table fan, packed with great features. Equipped with noise-reducing resin blades and corrosion-resistant, powder-coated metal guards, it offers a serene and dependable performance. Despite its robust motor and impressive speed capabilities, it offers a seamless and quiet oscillation experience.

PRODUCT CODE	FF 5103
SWEEP (mm)	400
POWER (W)	60
SPEED (RPM)	1350
AIR DELIVERY (cmm)	72

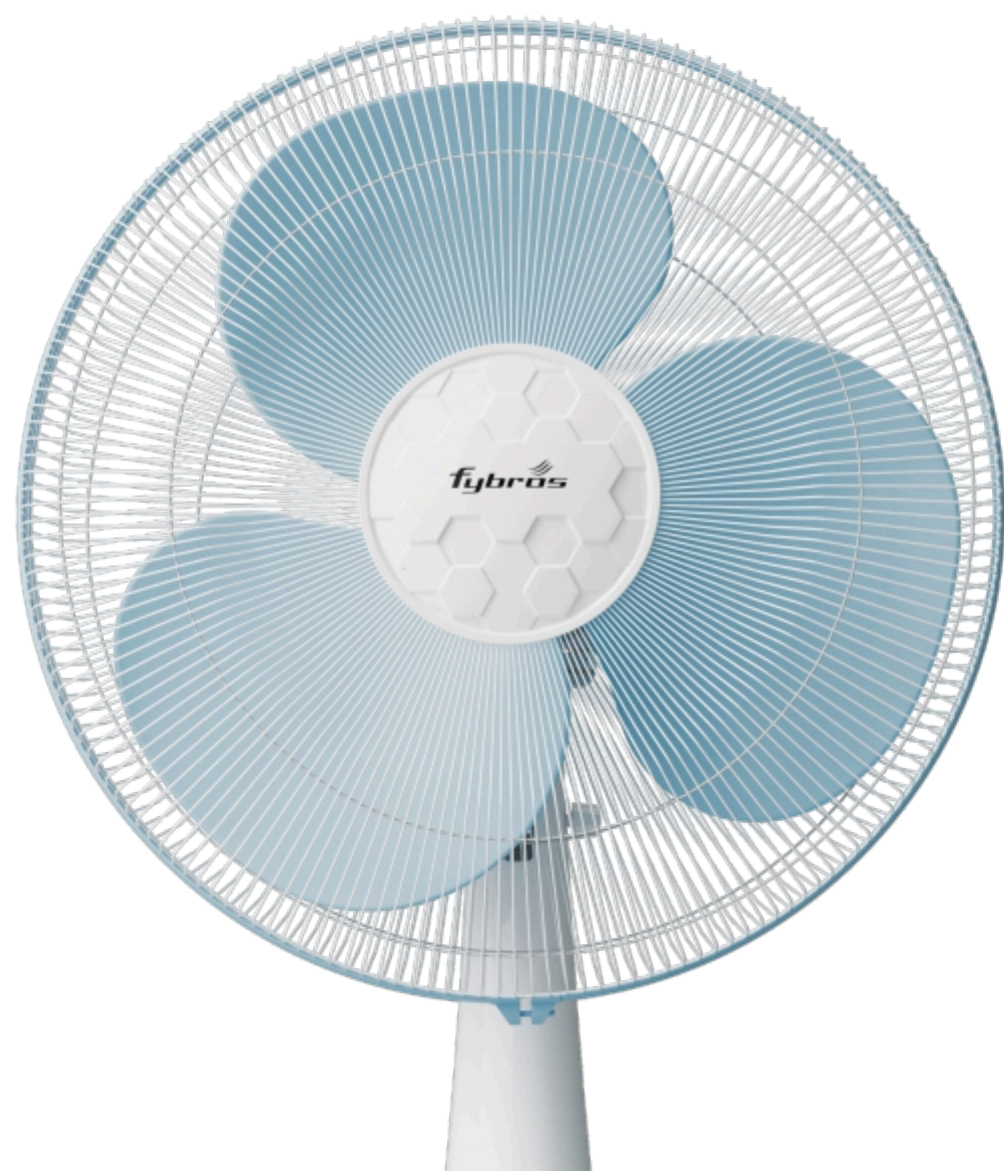

White Icy blue



3 SPEED MODES



90° LEFT / RIGHT OSCILLATION



BEST-IN-CLASS COPPER



AERODYNAMIC BLADES



STURDY BASE

- Aerodynamically designed Resin Blades
- Jerk Free Oscillation
- Rust Resistant Powder Coated Guards
- Robust Motor
- Best-in-Class Copper



NOOK PLUS Table Fan

NOOK PLUS Table Fan is equipped with advanced blades; which ensures efficient air circulation, while maintaining a whisper-quiet operation. Safety is paramount, with built-in thermal over load protector, providing peace of mind during prolonged use. Encased in powder-coated metal guards, this fan not only exudes durability but also complements your decor with its sleek design.

PRODUCT CODE	FF 5104
SWEEP (mm)	400 120
POWER (W)	2200 95
SPEED (RPM)	
AIR DELIVERY (cmm)	



White Burgundy



Black Burgundy

NOOK PLUS Table Fan

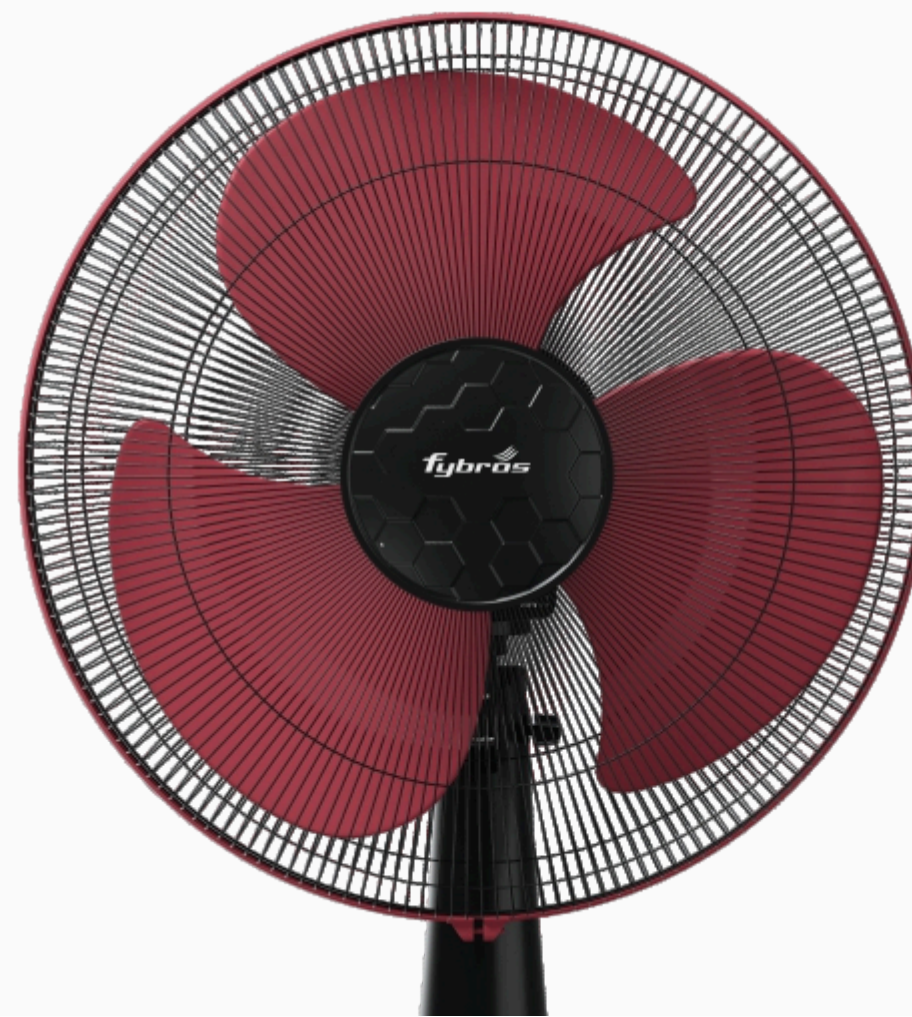

Aerodynamically designed Resin Blades
 Thermal Overload Protector
 Jerk Free Oscillation
 Rust Resistant Powder Coated Guards





VAYU Wall Fan



Black Orange



Fluorescent Blue

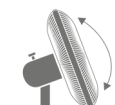

VAYU Wall Fan

Experience the VAYU Wall Fan, a sleek cooling solution. With resin blades for silent operation and powder-coated metal guards for durability, it's the perfect blend of performance and style. Experience the perfect blend of functionality and aesthetics with the VAYU Wall Fan.

PRODUCT CODE	FF 5201
SWEEP (mm)	400
POWER (W)	58
SPEED (RPM)	1330
AIR DELIVERY (cmm)	70

Aerodynamically designed Resin Blades
 Noiseless Operation Dual Cords for Speed & Oscillation Control Synchronous motor for smooth oscillation

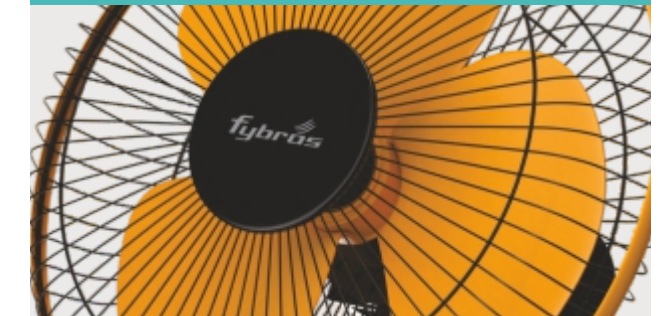

GUSH Wall Fan

Bid farewell to scorching heat and welcome the embrace of comfort with our Gush Wall fan. This fan is fitted with dependable synchronous motor for jerk free smooth oscillation and the motor comes with thermal over load protector.

PRODUCT CODE	FF 5202	
SWEEP (mm)	300	400
POWER (W)	75	110
SPEED (RPM)	2400	2200
AIR DELIVERY (cmm)	70	90

Aerodynamically designed Resin Blades
 Thermal Overload Protector
 Synchronous Motor for smooth oscillation
 Rust Resistant Powder Coated Guards
 Dual Cords for Speed & Oscillation Control



GUSH Wall Fan



Black Grey



White Grey



3 SPEED MODES



SUPER SPEED



90° LEFT / RIGHT OSCILLATION



BEST-IN-CLASS COPPER



AERODYNAMIC BLADES



SUPERIOR CORDS

NOOK Wall Fan

NOOK Wall Fan

Experience the NOOK Wall Fan, a sleek cooling solution. With resin blades for silent operation and powder-coated metal guards for durability, it's the perfect blend of performance and style. Experience the perfect blend of functionality and aesthetics with the NOOK Wall Fan.

PRODUCT CODE	FF 5204
SWEEP (mm)	400
POWER (W)	63
SPEED (RPM)	1350
AIR DELIVERY (cmm)	72

Aerodynamically designed Resin Blades
 Noiseless Operation Dual Cords for Speed
 & Oscillation Control Synchronous motor
 for smooth oscillation



White Pistachio



White Icy Blue

- 
3 SPEED MODES
- 
90° LEFT / RIGHT OSCILLATION
- 
BEST-IN-CLASS COPPER
- 
AERODYNAMIC BLADES
- 
TILT ANGLE ADJUSTABLE

2 YEARS WARRANTY

IS-302-2-80

 CM/L-6300115490



NOOK PLUS Wall Fan

Bid farewell to scorching heat and welcome the embrace of comfort with our NOOK PLUS Wall fan. This fan is fitted with dependable synchronous motor for jerk free smooth oscillation and the motor comes with thermal over load protector.

PRODUCT CODE	FF 5205
SWEEP (mm)	400 120
POWER (W)	2200 95
SPEED (RPM)	
AIR DELIVERY (cmm)	

- Aerodynamically designed Resin Blades
- Thermal Overload Protector
- Synchronous Motor for smooth oscillation
- Rust Resistant Powder Coated Guards
- Dual Cords for Speed & Oscillation Control



NOOK PLUS Wall Fan



White Burgundy

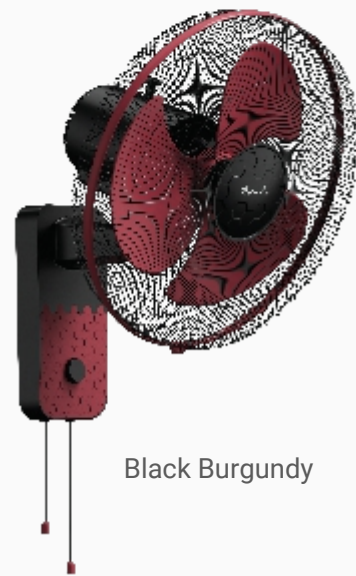

Black Burgundy



3 SPEED MODES



HIGH SPEED



90° LEFT / RIGHT OSCILLATION



BEST-IN-CLASS COPPER



AERODYNAMIC BLADES



SUPERIOR CORDS

IS-302-2-80



CM/L-6300115490



MAGNUM Wall Fan

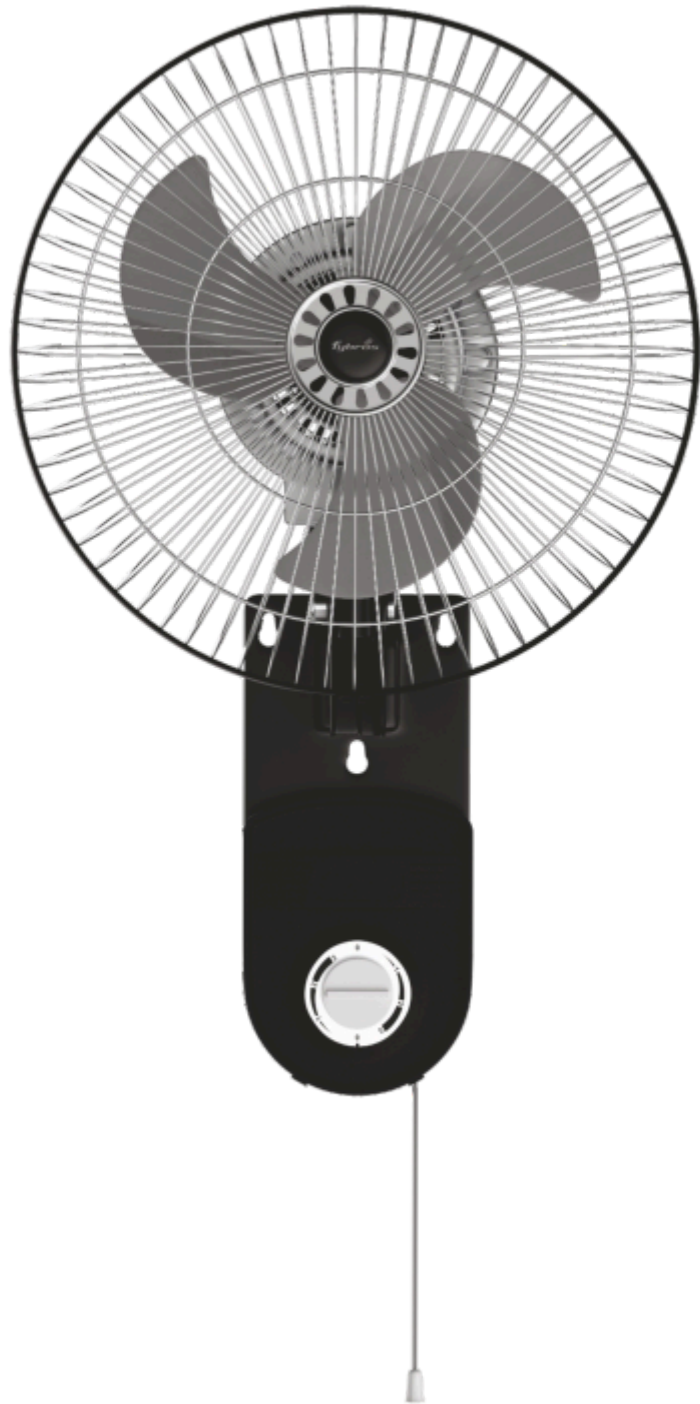

3 SPEED MODES



90° LEFT / RIGHT OSCILLATION



BEST-IN-CLASS COPPER



AERODYNAMIC BLADES

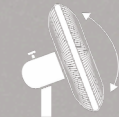

TILT ANGLE ADJUSTABLE

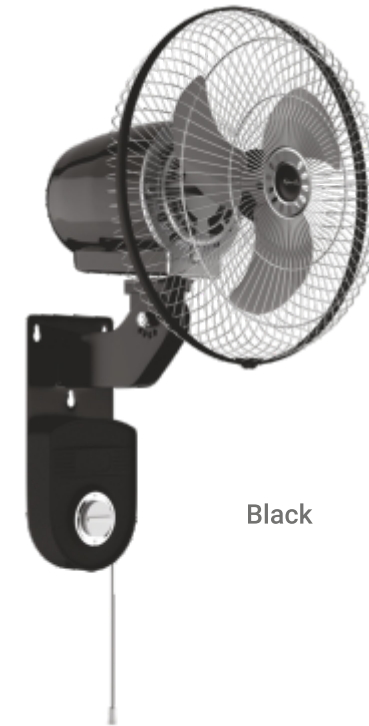

Black



MAGNUM Wall Fan

Showcasing the Magnum Wall fan, a pinnacle of cooling

comfort. With aluminium blades for efficient airflow, and high-grade copper motor and corrosion-resistant metal guards, it's the perfect blend of form and function for your spaces.

PRODUCT CODE	FF 5203
SWEEP (mm)	450
POWER (W)	95
SPEED (RPM)	1350
AIR DELIVERY (cmm)	110

Aluminium Blades Stylish Aesthetics
Rust Resistant Powder Coated Guards
Jerk Free Oscillation Heavy Duty motor





VAYU Pedestal Fan

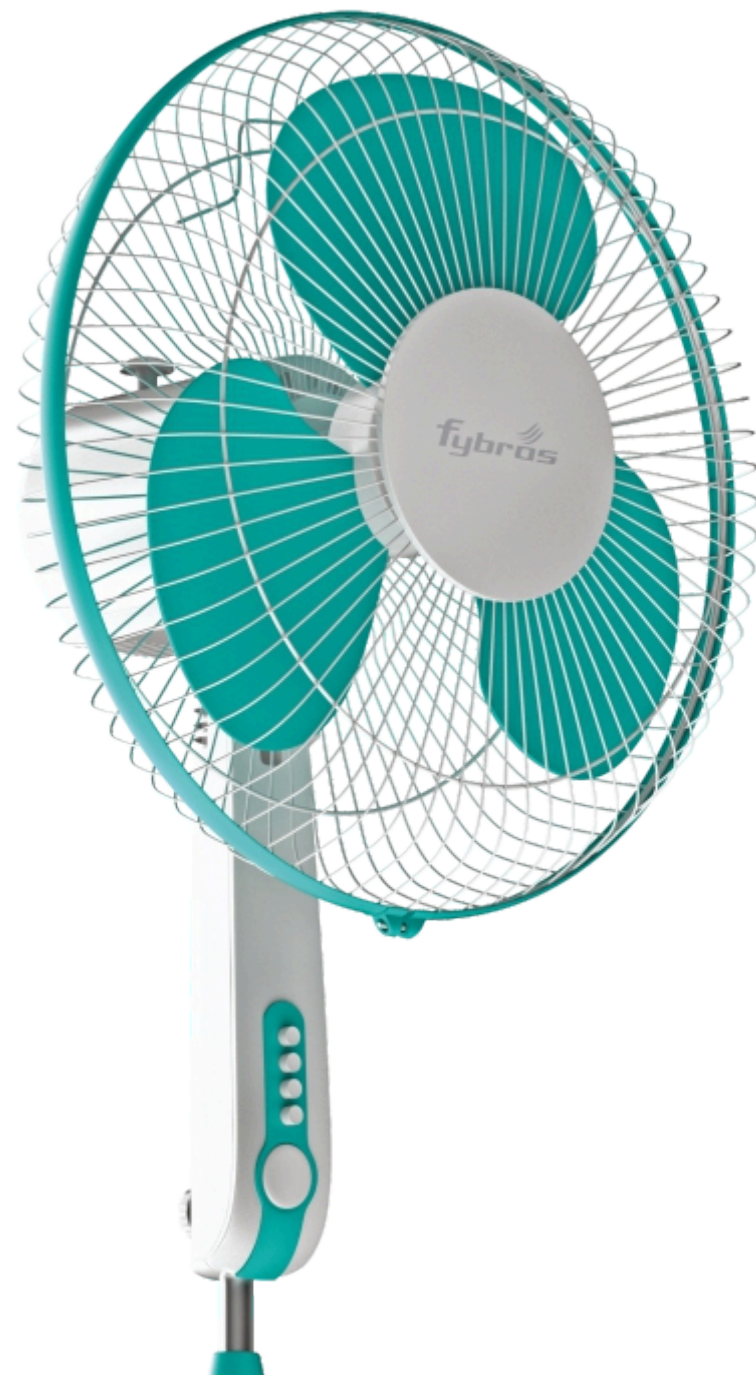

Black Orange



Fluorescent Blue



3 SPEED



STURDY
BASE



BEST-IN-CLASS
COPPER



AERODYNAMIC
BLADES

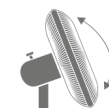

TILT ANGLE
ADJUSTABLE

VAYU Pedestal Fan

Designed for your comfort, VAYU Pedestal Fan boasts a set of remarkable features that redefine your cooling experience. Its precision-crafted blades ensure whisper-quiet operation, allowing you to enjoy cool, undisturbed moments. And with its convenient telescopic height adjustment, you have the flexibility to tailor the fan's position to your preferences.

PRODUCT CODE	FF 5301
SWEEP (mm)	400
POWER (W)	58
SPEED (RPM)	1330
AIR DELIVERY (cmm)	70

- Aerodynamically designed Resin Blades
- Jerk Free Oscillation
- Fully adjustable height
- Noiseless Operation
- Best-in-Class Copper

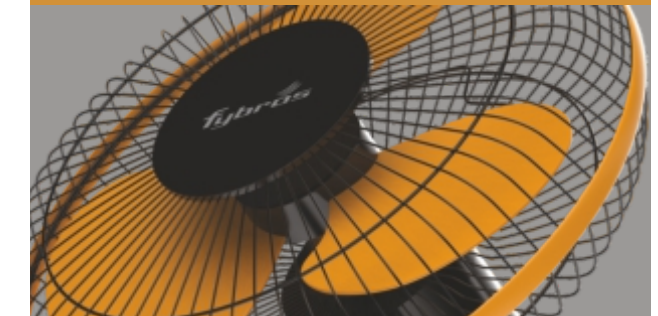

2 YEARS WARRANTY

IS-302-2-90
CTAL-6390119-898

GUSH Pedestal Fan

GUSH Pedestal Fan

Crafted with resin Decorative Blades, Gush Pedestal Fan not only adds a touch of elegance to your space but also ensures a tranquil atmosphere with its remarkably quiet operation. Its stunningly stylish and contemporary design seamlessly blends with any interior, making it the perfect choice for those who crave both form and function in their cooling solutions. Safety is paramount, with built-in thermal over load protector, providing peace of mind during prolonged use. Synchronous motor is provided to ensure smooth and uniform oscillation.

PRODUCT CODE	FF 5302
SWEEP (mm)	400 110
POWER (W)	2200 90
SPEED (RPM)	
AIR DELIVERY (cmm)	

- Unique and Modern Design
- Aerodynamically designed resin Blades
- High Air Thrust
- Fully adjustable height
- Rust Resistant Powder Coated Guards
- Synchronous motor for smooth oscillation

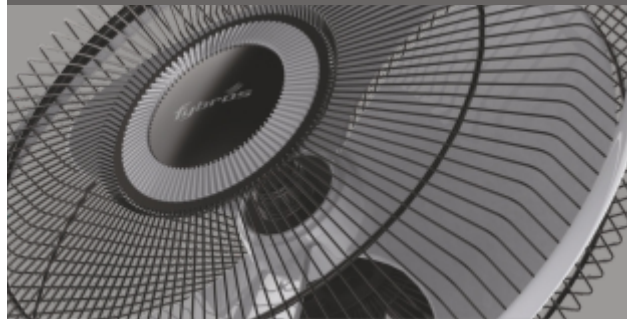

Black Grey



White Grey



- 3 SPEED
- SUPER SPEED
- STURDY BASE
- BEST-IN-CLASS COPPER
- AERODYNAMIC BLADES
- TILT ANGLE ADJUSTABLE

NOOK Pedestal Fan



White Pistachio

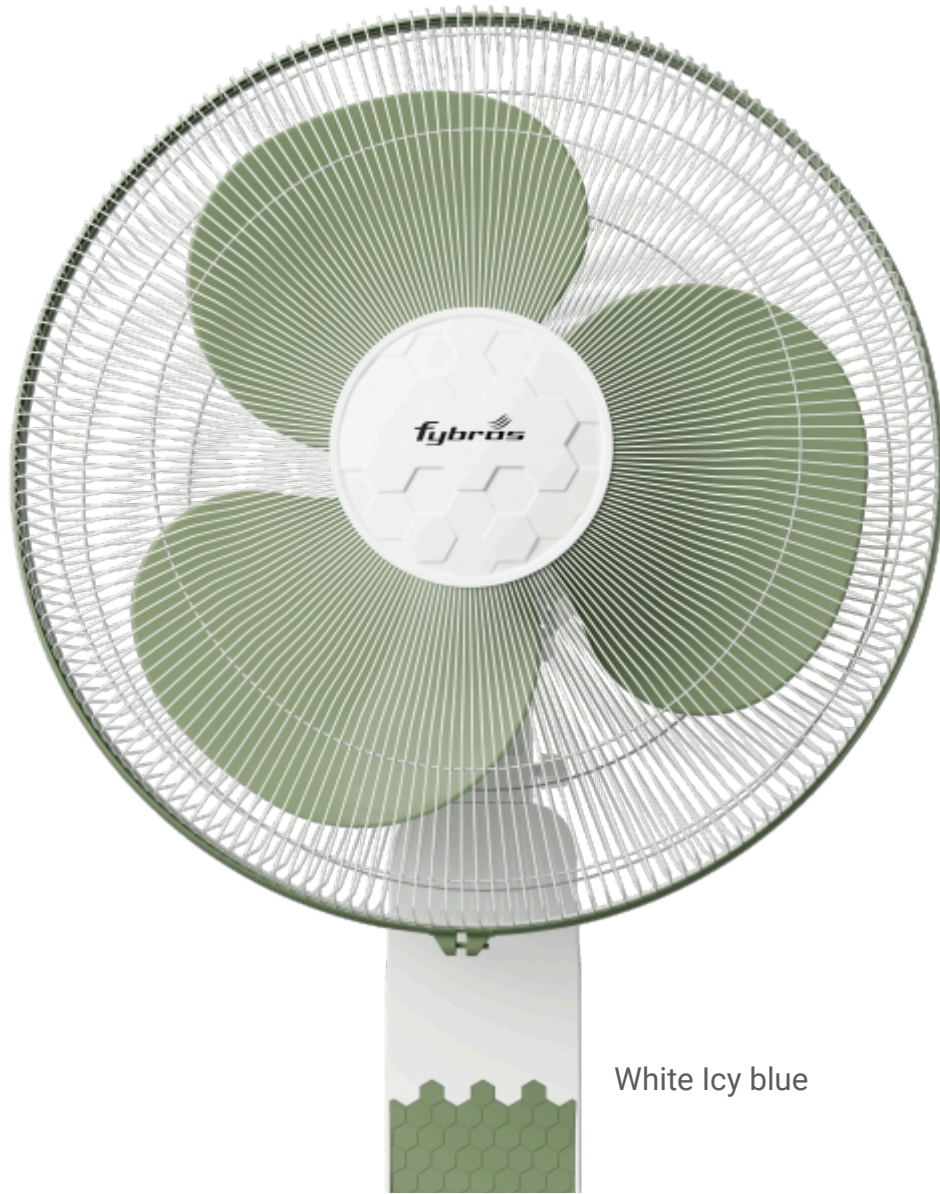

White Icy blue



White Icy blue



3 SPEED



STURDY BASE



BEST-IN-CLASS COPPER



AERODYNAMIC BLADES



TILT ANGLE ADJUSTABLE

NOOK Pedestal Fan

Designed for your comfort, NOOK Pedestal Fan boasts a set of remarkable features that redefine your cooling experience. Its precision-crafted blades ensure whisper-quiet operation, allowing you to enjoy cool, undisturbed moments. And with its convenient telescopic height adjustment, you have the flexibility to tailor the fan's position to your preferences.

PRODUCT CODE	FF 5303
SWEEP (mm)	400
POWER (W)	60
SPEED (RPM)	1350
AIR DELIVERY (cmm)	72

- Aerodynamically designed resin Blades
- Jerl Free Oscillation
- Fully adjustable height
- Noiseless Operation
- Best-in-Class Copper

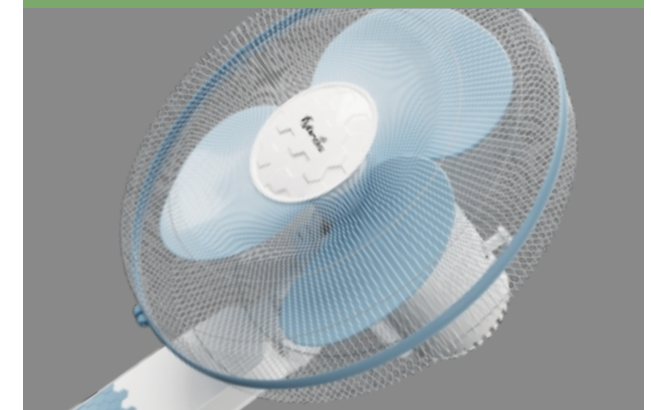

NOOK PLUS

Crafted with resin Decorative Blades, NOOK PLUS Pedestal Fan not only adds a touch of elegance to your space but also ensures a tranquil atmosphere with its remarkably quiet operation. Its stunningly stylish and contemporary design seamlessly blends with any interior, making it the perfect choice for those who crave both form and function in their cooling solutions. Safety is paramount, with built-in thermal over load protector, providing peace of mind during prolonged use.

PRODUCT CODE	FF 5304
SWEEP (mm)	400 120
POWER (W)	2200 95
SPEED (RPM)	
AIR DELIVERY (cmm)	

Unique and Modern Design
 Aerodynamically designed resin Blades
 High Air Thrust
 Fully adjustable height
 Rust Resistant Powder Coated Guards



White Burgundy



Black Burgundy

NOOK PLUS Pedestal Fan

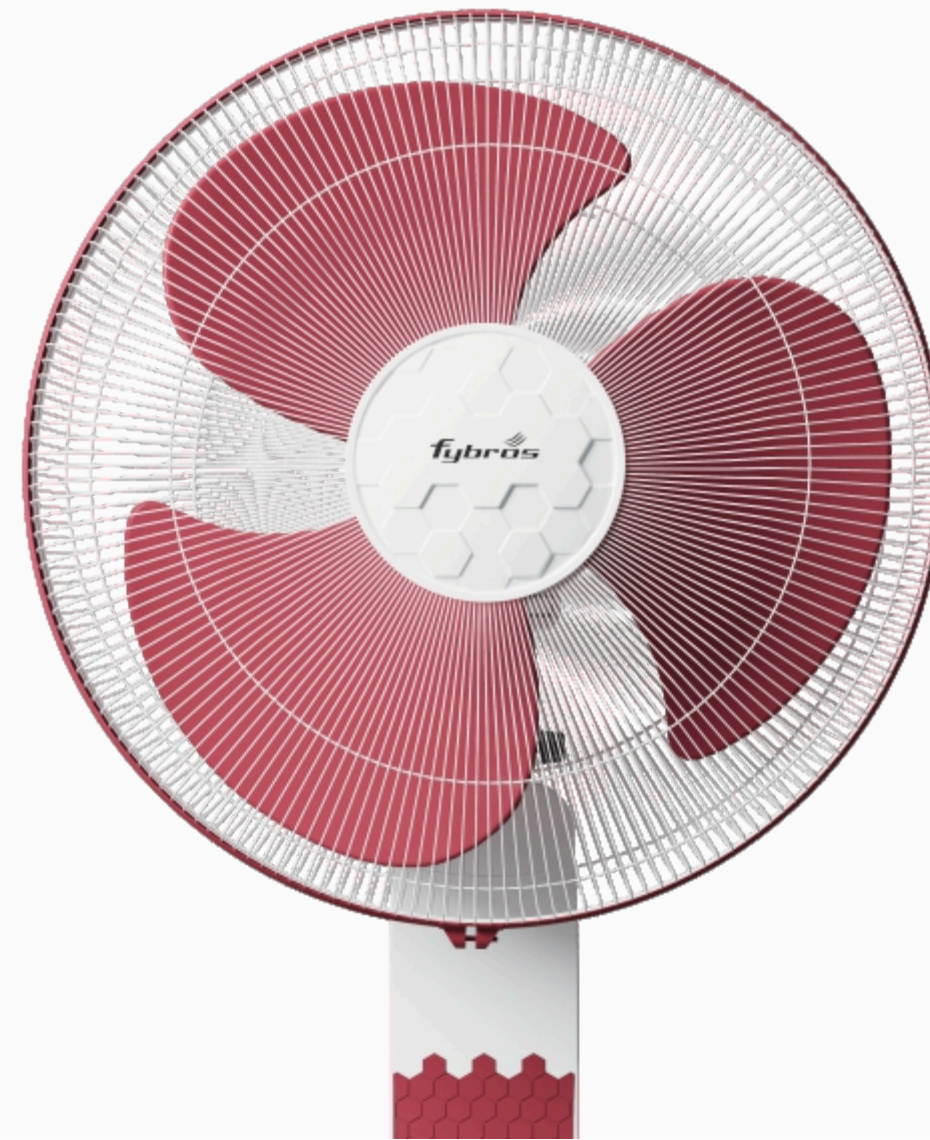

3 SPEED



HIGH SPEED



STURDY BASE



BEST-IN-CLASS COPPER



AERODYNAMIC BLADES



TILT ANGLE ADJUSTABLE

IS-302-2-80



CM/L-6300115490

2 YEARS WARRANTY

F-SPIN Pedestal Fan

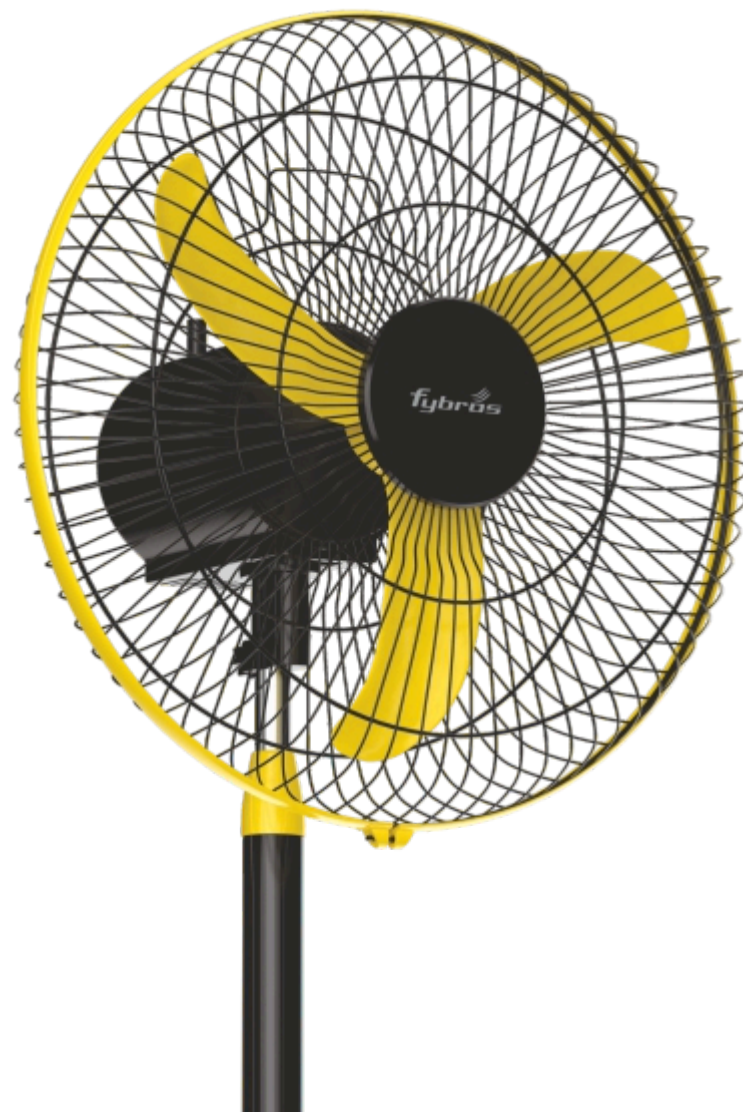

Black Yellow

- 
3 SPEED MODES
- 
STURDY BASE
- 
BEST-IN-CLASS COPPER
- 
PREMIUM QUALITY
- 
AERODYNAMIC BLADES

F-SPIN Pedestal Fan

Presenting our Elegant & Contemporary F-Spin Pedestal Fan, where refinement meets functionality. Delight in its seamless oscillation and noiseless operation. Equipped with aerodynamic blades, this fan ensures efficient air circulation. The powder-coated guards not only boost durability but also add a touch of sophistication to your surroundings.

PRODUCT CODE	FF 5401
SWEEP (mm)	400 125
POWER (W)	2200
SPEED (RPM)	105
AIR DELIVERY (cmm)	

- Aesthetically Designed
- ABS Blades
- High Air Thrust
- Jerk Free Oscillation
- Rust Resistant Powder coated Guards
- Fully adjustable height

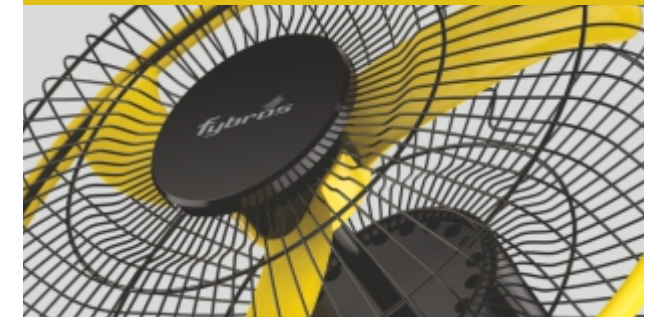



F SPIN-3 Pedestal Fan

F SPIN-3 Pedestal Fan

Presenting our Elegant & Contemporary F-Spin-3 Pedestal Fan, where refinement meets functionality. Delight in its seamless oscillation and noiseless operation. Equipped with aerodynamic blades, this fan ensures efficient air circulation. The powder-coated guards not only boost durability but also add a touch of sophistication to your surroundings.

PRODUCT CODE	FF 5404
SWEEP (mm)	400 115
POWER (W)	2200
SPEED (RPM)	110
AIR DELIVERY (cmm)	

- Aesthetically Designed
- ABS Blades
- High Air Thrust
- Jerk Free Oscillation
- Rust Resistant Powder Coated Guards
- Fully adjustable height

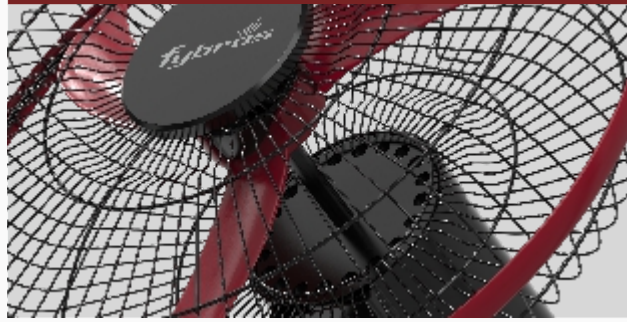

Black Burgundy



3 SPEED MODES



HIGH SPEED



STURDY BASE



PREMIUM QUALITY



AERODYNAMIC BLADES



IS-302-2-80
CML-951255722

MAGNUM Pedestal Fan

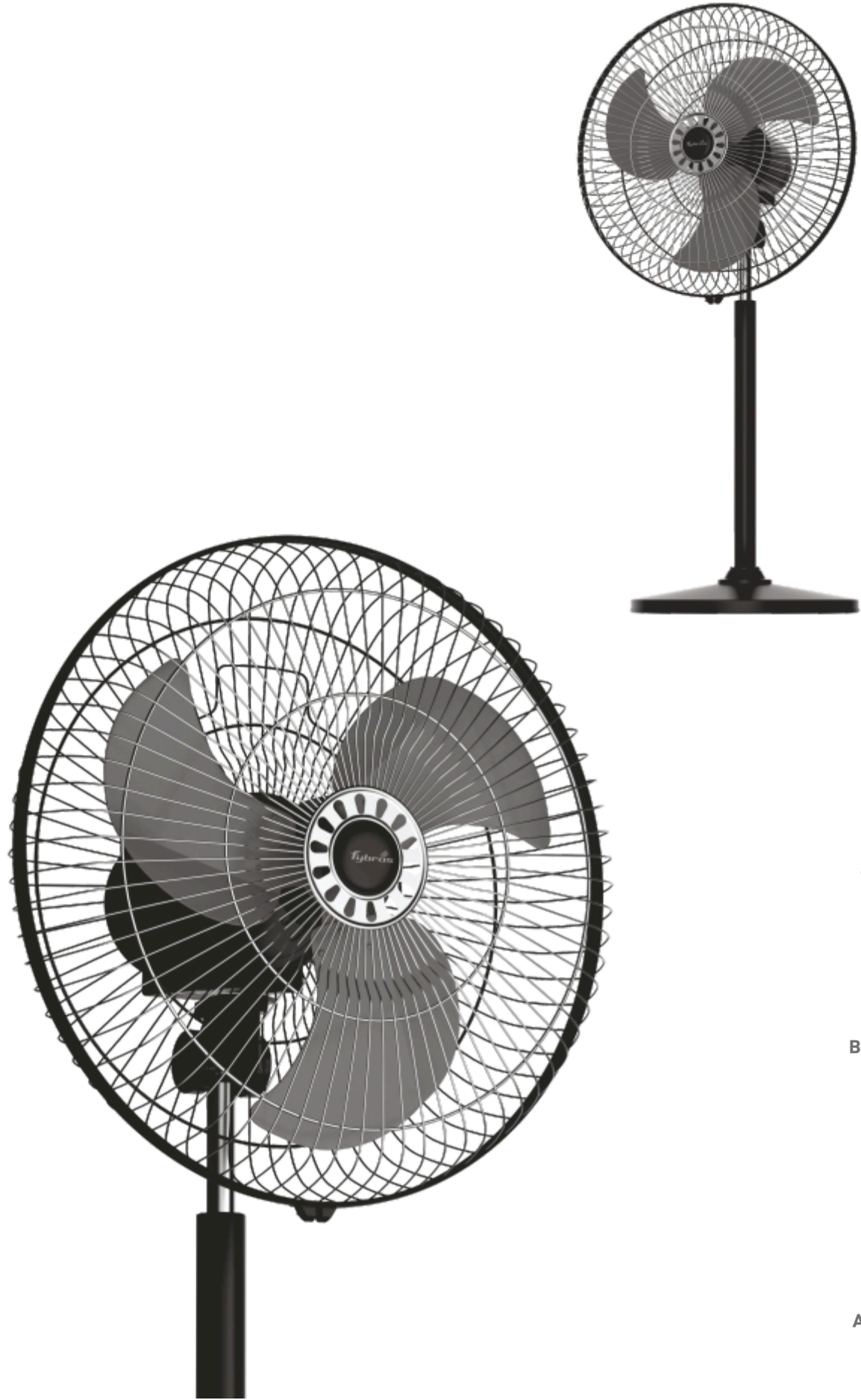

- 3 SPEED MODES
- STURDY BASE
- BEST-IN-CLASS COPPER
- PREMIUM QUALITY
- AERODYNAMIC BLADES



Black

MAGNUM

Showcasing the Magnum Pedestal fan, a pinnacle of cooling comfort. With aluminium blades for efficient airflow, silent and jerk-free operation, height adjustment, high-grade copper motor, and corrosion resistant metal guards, it's the perfect blend of form and function for your spaces.

PRODUCT CODE	FF 5402
SWEEP (mm)	450
POWER (W)	95
SPEED (RPM)	1350
AIR DELIVERY (cmm)	110

Aluminium Blades Stylish Aesthetics
 Jerk Free Oscillation Rust Resistant
 Powder Coated Guards Fully
 Adjustable Height Sturdy Metal Base



2 YEARS WARRANTY

IS-302-1-30

 CML-0166238787

THUNDER

Introducing an avant-garde ThunderFarrata fan,

distinguished by its contemporary aesthetics. Adorned with powder-coated guards, it boasts of robust metal base for stability. Its aerodynamic metal blades ensure efficient & powerful cooling, while offering three distinct modes of operation for tailored comfort.

PRODUCT CODE	FF 5403
SWEEP (mm)	500 140
POWER (W)	1350
SPEED (RPM)	100
AIR DELIVERY (cmm)	

Aluminium Blades
Steady Design
Rust Resistant Body
Fully Adjustable Height
Sturdy Metal Base



Dark Grey

THUNDER Pedestal Fan



3 SPEED
MODES



STURDY
BASE



BEST-IN-CLASS
COPPER



PREMIUM
QUALITY



AERODYNAMIC
BLADES

THUNDER-3 Pedestal Fan



Dark Grey

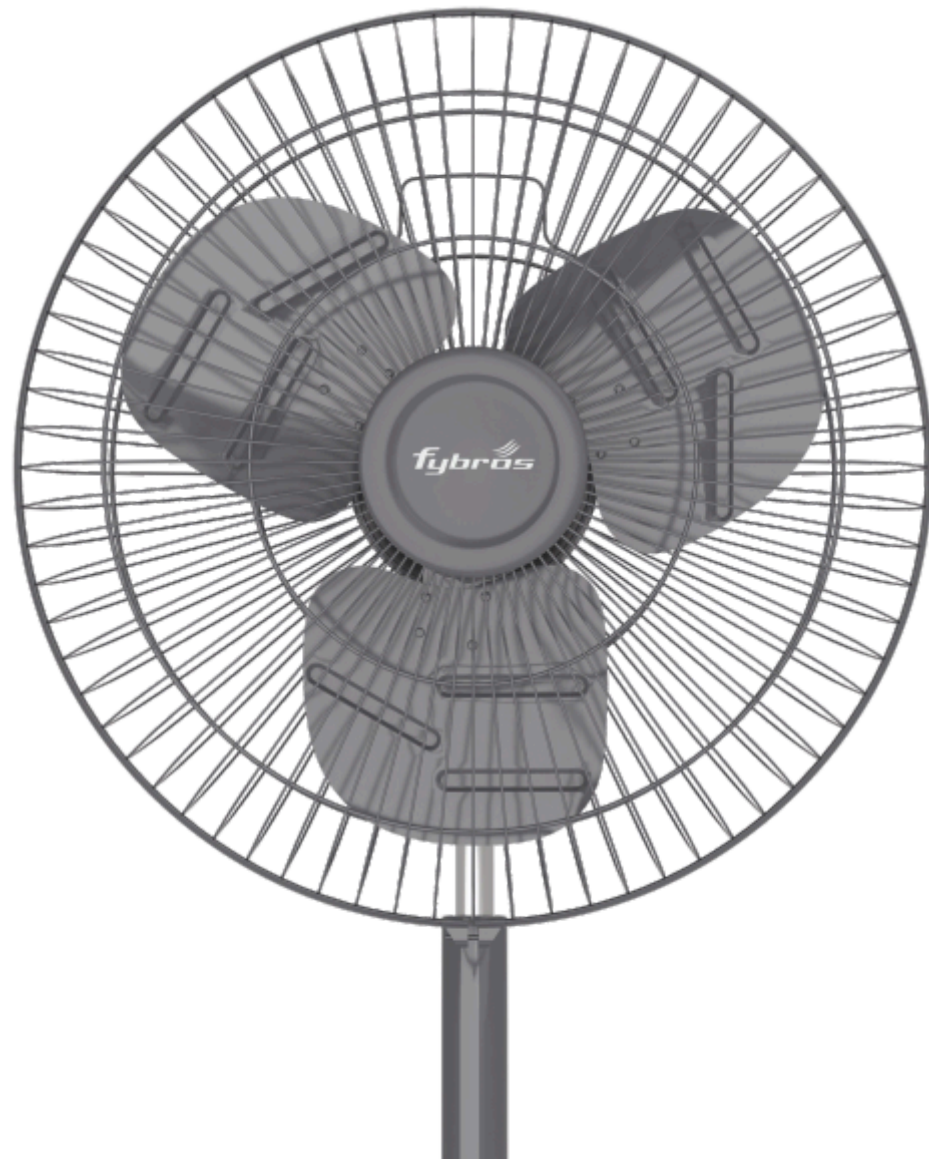

THUNDER-3

Introducing an avant-garde Thunder-3 pedestal fan,

distinguished by its contemporary aesthetics. Adorned with powder-coated guards, it boasts of robust metal base for stability. Its aerodynamic metal blades ensure efficient & powerful cooling, while offering three distinct modes of operation for tailored comfort.

PRODUCT CODE	FF 5405
SWEEP (mm)	500 145
POWER (W)	1350
SPEED (RPM)	120
AIR DELIVERY (cmm)	

Aluminium Blades
 Steady Design
 Rust Resistant Body
 Fully Adjustable Height
 Sturdy Metal Base

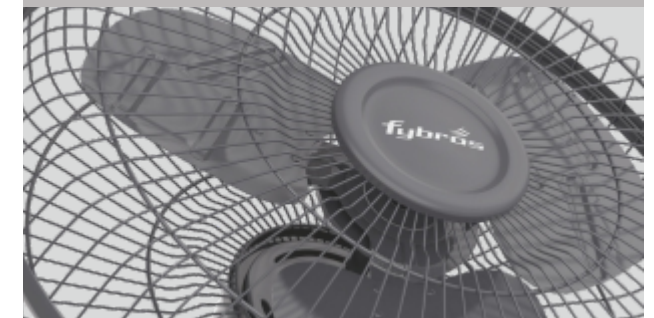

LUNA

2X2CeilingMounted Box Fan

The Luna 2x2 Ceiling mounted box fan is ideal for fitting in places of 2 x 2 ceiling tiles in offices, cabins, Hospitals and homes. It comes with light that illuminates in three colours and can be conveniently controlled via remote

PRODUCT CODE	FF 5801
SWEEP (mm)	400 80
POWER (W)	1300
SPEED (RPM)	2400
AIR DELIVERY (cmh)	

- Sleek & Stylish
- Robust Motor
- Light Weight
- Noiseless Operation
- Low Wattage
- Detachable Front Panel For Easy Cleaning



White

LUNA

2X2CeilingMounted Box Fan



LOW CEILING HEIGHT SOLUTION



ALL FUNCTION REMOTE



POWER SAVING MULTIPLE LED LIGHTS



LOW & HIGH SPEED FUNCTION



EASY & HASSLE FREE MOUNTING



GRILL FOR PROTECTION AND SPREADING AIR



IS-302-2-80

 CM/L-8530115013

SILO Tower Fan

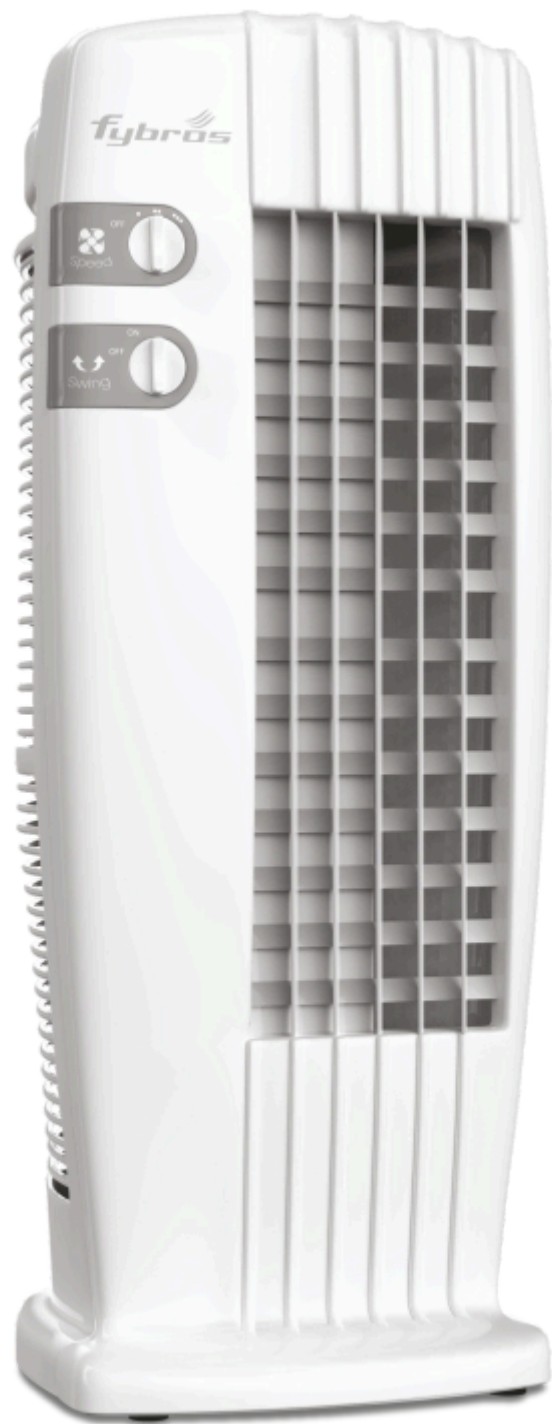

White Grey

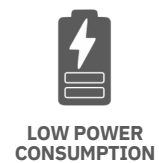

SILO Tower Fan

The SILO high-speed tower fan is a sleek, space-saving cooling solution designed for modern interiors. With adjustable speed settings, it delivers powerful airflow to cool rooms quickly and efficiently. Its lightweight construction ensures easy portability, while the quiet operation makes it ideal for bedrooms and offices. Perfect for combating summer heat.

PRODUCT CODE	FF 5901
SWEEP (mm)	-- 150
POWER (W)	1350
SPEED (RPM)	2250
AIR DELIVERY (CMH)	

- Heavy Duty Motor For Longer Life
- Equipped With 3 Speed Control & Oscillation Functions
- Air Throw Distance Up to 25 FT
- Ergonomic Control Panel For Ease of Operations
- Sturdy Design For Vibration Free Oscillation
- Portable Unit With Easy to Hold Slot



GALE Cabin Fan

GALE Cabin Fan

Experience our compact GALE Cabin Fan your portable cooling solution. This mini foldable fan operates quietly, is rust-resistant for durability, and charges conveniently via USB. Customize your comfort with its adjustable tilt mechanism. Stay cool on the go.

PRODUCT CODE	FF 5501
SWEEP (mm)	300
POWER (W)	75
SPEED (RPM)	2200
AIR DELIVERY (CMM)	60



Designed for Modern Spaces
 Easy to Carry & Install
 High Air Thrust gives quick cooling
 360 Degree Rotating Grill with
 Clockwise & Anti-clockwise movement

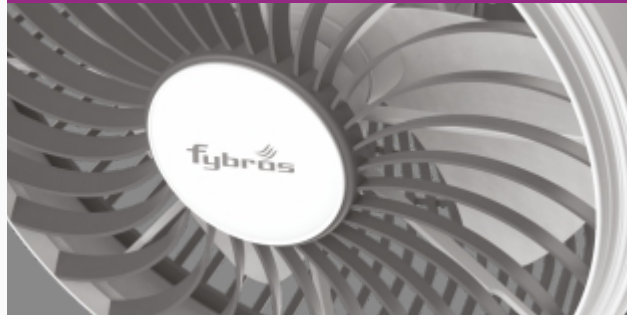

ROBUST MOTOR



SUPER SPEED



TILT ANGLE ADJUSTABLE



AERODYNAMIC BLADES

IS-302-2-80



CM/L-9600092218





TRI AIR Personal Fan



Black Yellow

-  PREMIUM QUALITY
-  SUPER SPEED
-  AERODYNAMIC BLADES
-  BEST-IN-CLASS COPPER

TRI AIR Personal Fan

The Air personal fan is the ultimate solution for all your

cooling needs. Designed to deliver a powerful stream of air, it provides immediate relief from sweltering heat. The Tri Air fan is built to last, constructed with best-in-class copper for ensured durability. It's not just about function; it's a stylish accessory that adds a touch of flair to your space.

PRODUCT CODE	FF 5601
SWEEP (mm)	225
POWER (W)	45
SPEED (RPM)	2500
AIR DELIVERY (cmm)	25

- Aerodynamically designed Resin Blades
- Robust Motor
- Best-in-Class Copper
- Sleek & Stylish



HANDY GUST

Handy Gust, true to its name, delivers a strong flow of air wherever you need it. This modern marvel features a 360-degree rotating grill, clockwise and counter clockwise movement, and an adjustable angle for customizable airflow. Designed for modern spaces, it's easy to carry and install, boasting a high air thrust for rapid cooling. With its super-speed setting, Handy Gust is the ultimate cooling companion that combines efficiency with contemporary style.

PRODUCT CODE	FF 5701
SWEEP (mm)	150
POWER (W)	35
WIND SPEED (m/s)	5.5

- Mini Foldable Fan
- Noiseless Operation
- Rust Resistant
- Adjustable Upward & Downward Tilt Mechanism



White Grey

HANDY GUST



- PREMIUM QUALITY
- ADJUSTABLE ANGLE
- 90° LEFT / RIGHT OSCILLATION
- AERODYNAMIC BLADES
- TILT ANGLE ADJUSTABLE
- PORTABLE

Exhaust Fans



ZEST Axial Fan

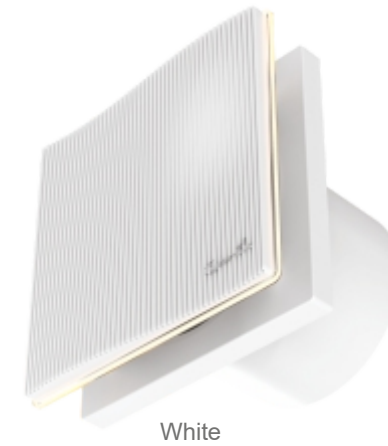
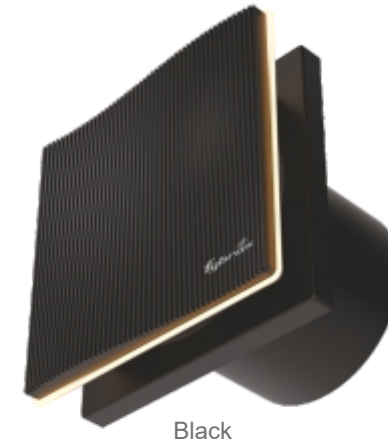

ZEST Axial Fan

Embrace cutting-edge home ventilation with Zest. This modern axial fan, featuring resin blades, is designed specifically for contemporary homes. Zest operates silently yet efficiently, providing powerful air ventilation. Its user-friendly installation and energy-efficient design make it the perfect choice for your home. Circular back grill ensure easy installation in glass avoiding cutting holes in walls and civil work.

PRODUCT CODE	FF 6101
SWEEP (mm)	150
POWER (W)	22
SPEED (RPM)	1800
AIR DELIVERY (CMH)	250

- Designed for Modern Homes
- Elevates the Ambience with Integrated Peripheral LED Light
- Resin Blades
- Thermal Overload Protector
- Quiet & Durable
- Strong Ventilation

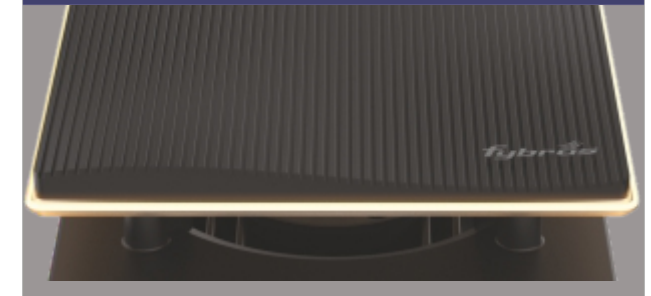

ENOR Axial Fan

The Enor axial fan epitomizes both durability and elegance. This synergy empowers you to maintain a refreshing interior ambiance by effectively expelling undesirable smoke and odours. Circular back grill ensure easy installation in glass avoiding cutting holes in walls and civil work.

PRODUCT CODE	FF 6102
SWEEP (mm)	150
POWER (W)	22
SPEED (RPM)	1800
AIR DELIVERY (CMH)	250

- Design for Modern Homes
- Efficient Motor
- Noiseless Operation
- Low Wattage
- Detachable front panel for easy cleaning
- Automatic dust protection
Shutters for hassle-free hygiene

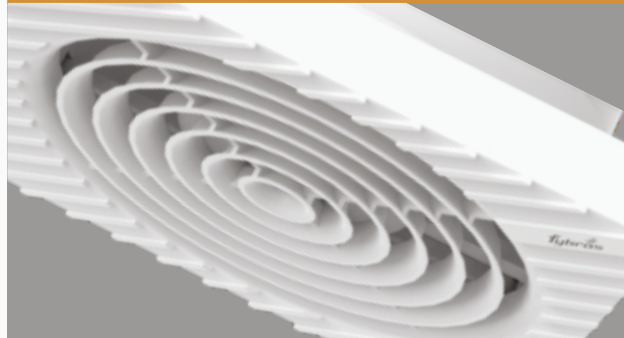

White

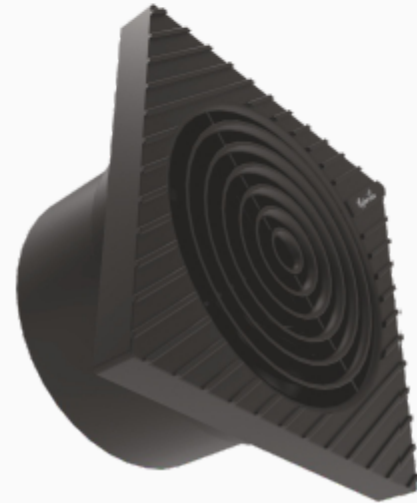

Black

ENOR Axial Fan



STRONG AIR VENTILATION



ROBUST MOTOR



EASY INSTALLATION



SUPER SPEED



LUSH Axial Fan



Black



Ivory



STRONG AIR VENTILATION



ROBUST MOTOR



EASY INSTALLATION



SUPER SPEED

LUSH Axial Fan

The Lush axial fan delivers seamless and efficient performance, while also being energy-efficient thanks to its sturdy motor. Constructed from durable yet lightweight resin blades, this fan seamlessly blends into your home or office environment. Its timeless front shield design effortlessly complements its surroundings. Circular back grill ensure easy installation in glass avoiding cutting holes in walls and civil work.

PRODUCT CODE	FF 6103	
SWEEP (mm)	100	150
POWER (W)	18	22
SPEED (RPM)	2200	1800
AIR DELIVERY (CMH)	90	250

- Sleek & Stylish
- Robust Motor
- Light Weight
- Noiseless Operation
- Low Wattage
- Detachable Front panel for easy cleaning

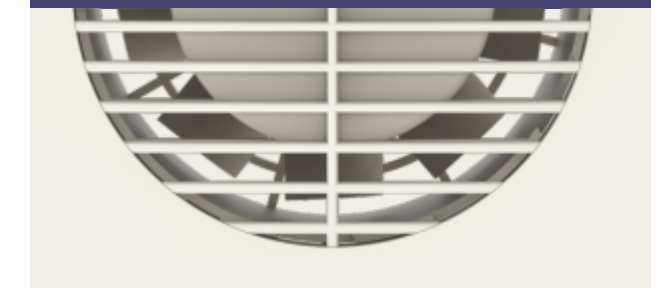

VENTFLO Ventilation Fan

VENTFLO

Discover our Ventflo ventilation fan that combines robust performance with user-friendly features. Its steady design, dust protection louvers, and easy-to-clean detachable front panel ensure longevity and cleanliness. This fan operates quietly and efficiently, with high exhaust power and super-speed settings for rapid air circulation. Easy installation and energy efficiency make it a top choice for any space.

PRODUCT CODE	FF 6201		
SWEEP (mm)	150	200	250
POWER (W)	35	38	40
SPEED (RPM)	1350	1300	1250
AIR DELIVERY (CMH)	280	550	750



White



Black



- Steady Design
- Robust Motor
- Dust Protection Louvers Enhances Longevity
- Detachable Front Panel For Easy Cleaning
- Quiet & Durable



STRONG AIR VENTILATION



ROBUST MOTOR



EASY INSTALLATION



ENERGY EFFICIENT



NOISELESS OPERATION



VENTI AIR Ceiling Ventilation Fan



White



STRONG AIR VENTILATION



ROBUST MOTOR



EASY INSTALLATION



ENERGY EFFICIENT



NOISELESS OPERATION

VENTI AIR Ceiling Ventilation Fan

Enhance the air flow within your living space using a Venti Air ceiling ventilation fan. Its curved blades effectively promote air circulation, removing stagnant air and introducing a refreshing breeze. It is also designed with contemporary spaces in mind, combining innovative features with easy maintenance.

PRODUCT CODE	FF 6301
SWEEP (mm)	200
POWER (W)	35
SPEED (RPM)	1350
AIR DELIVERY (CMH)	200

- Specially made for ceilings
- Low Wattage
- Detachable Front panel for easy cleaning
- Designed for Modern Spaces
- Quiet & Durable
- Strong Ventilation



EXFLO PLUS

Elevate your space with the Exflo Plus Fan, where power, speed, and reliability combine to offer exceptional ventilation. With increased wattage and higher-speed functionality, it is designed to deliver superior performance, efficiently expelling unwanted air and moisture. The robust motor remains at its core, now operating with even greater power. Its rust-resistant powder-coated guards, along with a steady bird guard, ensures long lasting protection.

PRODUCT CODE	FF 6401	
SWEEP (mm)	150	225
POWER (W)	40	70
SPEED (RPM)	2350	2500
AIR DELIVERY (CMH)	350	1050



Dark Grey

EXFLO PLUS Exhaust Fan



- Robust Motor
- Rust Resistant Powder Coated Guard
- Steady Bird Guard
- Rubber Gasket to eliminate vibrations



STRONG AIR VENTILATION



ROBUST MOTOR



EASY INSTALLATION



SUPER SPEED

IS-302-2-80



CML-6300114185



EXFLO Exhaust Fan



Dark Grey

- PREMIUM QUALITY
- STRONG AIR VENTILATION
- ROBUST MOTOR
- EASY INSTALLATION
- NOISELESS OPERATION

EXFLO Exhaust Fan

Featuring the Exflo Exhaust Fan, the epitome of reliability and functionality for all your ventilation needs. With its robust motor at the core, it ensures efficient and consistent airflow, while the rust-resistant, powder-coated guards guarantee longevity even in challenging environments. The steady bird guard provides extra protection, preventing unwanted visitors. Thanks to the rubber gasket, vibrations are eliminated, ensuring a peaceful and quiet operation.

PRODUCT CODE	FF 6402	
SWEEP (mm)	225	300
POWER (W)	35	45
SPEED (RPM)	1350	1350
AIR DELIVERY (CMH)	750	1150

- Robust Motor
- Rust Resistant Powder Coated Guard
- Steady Bird Guard
- Rubber Gasket to eliminate vibrations



Optimal Ceiling Height

Use ceiling fans for rooms with tall ceilings, and choose personal or wall fans, for rooms with low height ceilings.

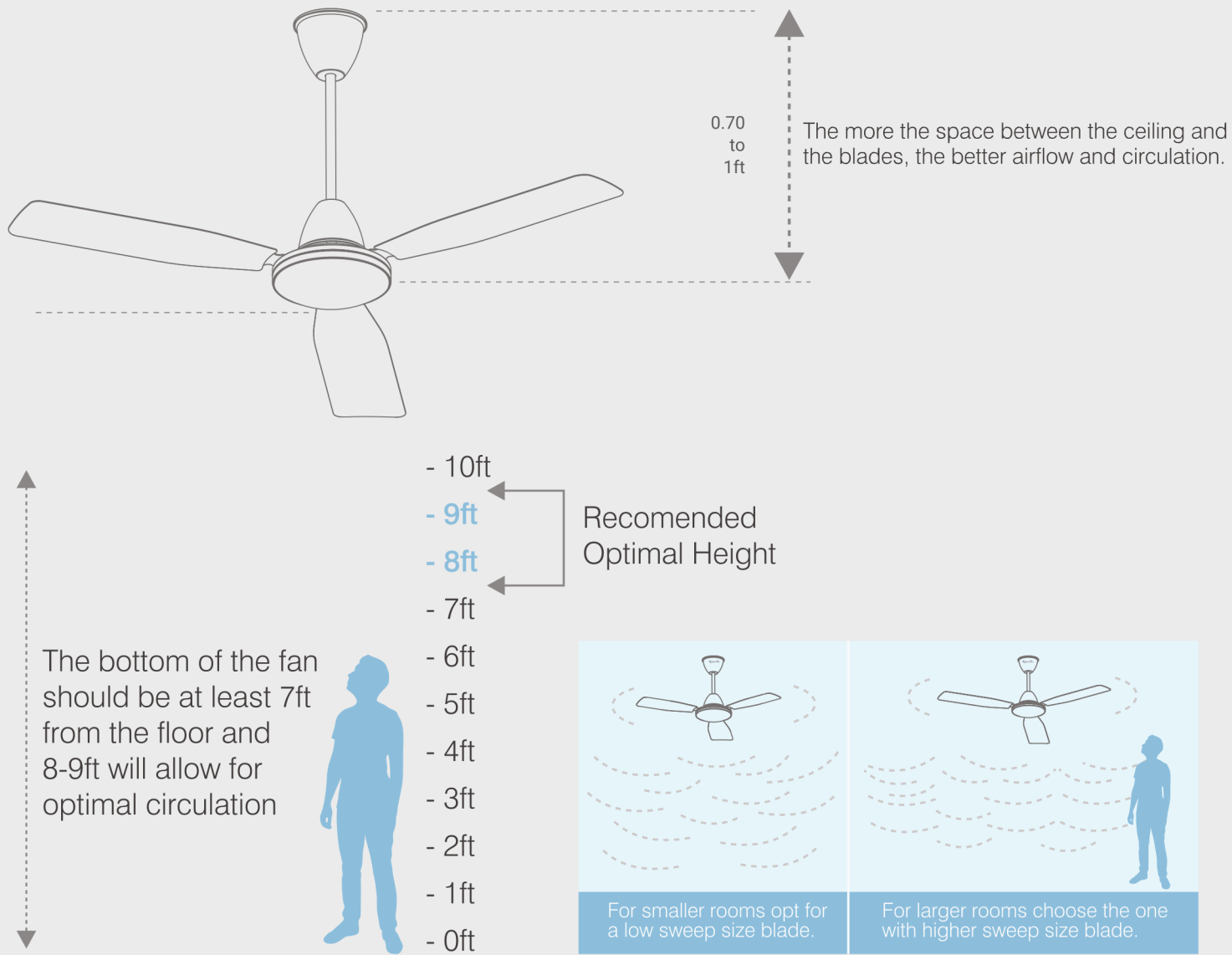

For large Hall, Auditoriums, offices, install two or more Ceiling fans with a space as specified below.

Sweep of Fan	Center Distance
900 mm (0.90m)	6 Feet
1050 mm (1.05m)	7 Feet
1200 mm (1.20m)	8 Feet
1400 mm (1.40m)	10 Feet

HOW TO SELECT FYBROS CEILING / EXHAUST FANS ACCORDING TO THE ROOM SIZE*



SWEEP SIZE	ROOM SIZE
60 cm (600 mm)	2.4 x 2 to 2.4 x 3m (8 x 6.5 to 8 x 10ft)
90 cm (900 mm)	2.4 x 3 to 3.3 x 3m (8 x 10 to 11 x 10ft)
1.2 m (1200 mm)	3 x 4 to 4 x 4m (10 x 12 to 11 x 10ft)
1.4 m (1400 mm)	4 x 5 to 5 x 5m (13 x 15 to 16 x 15ft)

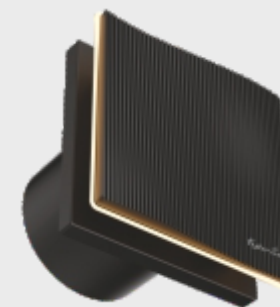
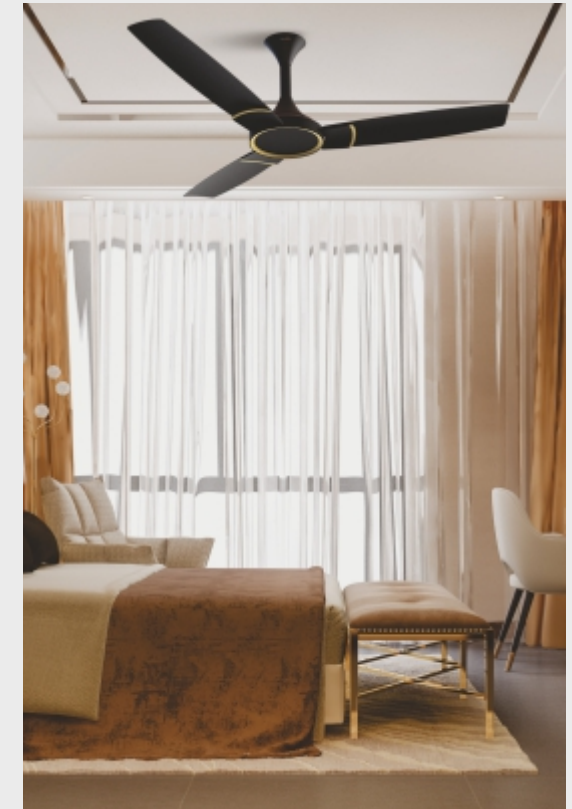

SWEEP SIZE	ROOM SIZE
10 cm (100 mm)/ 20 cm (200 mm)	2 x 2 x 3m (6 x 6 x 9ft)
15 cm (150 mm)/ 20 cm (200 mm)	
22.5 cm (225 mm)/ 20 cm (200 mm)	3 x 2.4 x 3m (10 x 8 x 9ft)
30 cm (300 mm)	





F-WAVE



GREZIA



BRISA



ELLA



SILENT WAVE



URUS



CASA PLUS



CASA BLDC



OLYMPIA



AERO



SOLIS

CEILING FANS

5 decades of Legacy, Faith & Brilliance



AERIS ART



AERIS PRO



AERIS



LOFT



STELLA



F-FLOW PRO



AIR-1 PRO



AIR-1



FALCON SS



F-FLOW



YALE



NIMO



VELO



MENOR



VAYU TABLE GUSH TABLE NOOK TABLE NOOK PLUS TABLE VAYU WALL

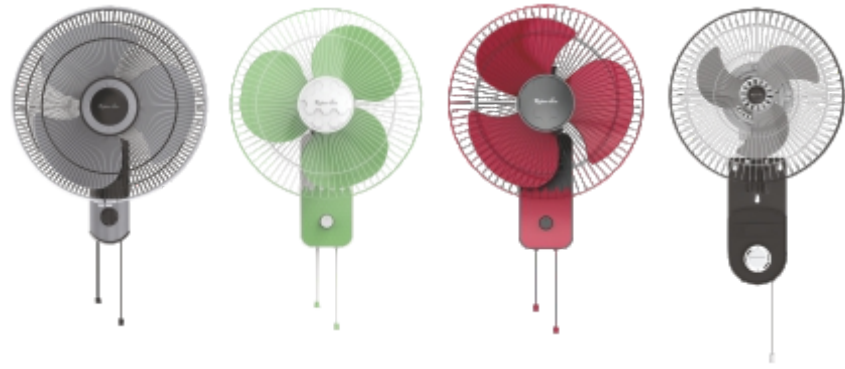

GUSH WALL NOOK WALL NOOK PLUS WALL MAGNUM WALL



GLIDE SILO LUNA 2X2



TRI AIR HANDY GUST GALE

PORTABLE F A N S

BLADELESS \ PORTABLE \ EXHAUST FANS



VAYU PEDESTAL GUSH PEDESTAL NOOK PEDESTAL NOOK PLUS PEDESTAL F-SPIN PEDESTAL



F SPIN-3 PEDESTAL MAGNUM PEDESTAL THUNDER PEDESTAL THUNDER-3 PEDESTAL



ZEST ENOR LUSH VENTFLO



VENTI AIR EXFLO PLUS EXFLO

TECHNICAL DETAILS

Bladeless Fan

CATEGORY	PRODUCT CODE	PRODUCT NAME	SWEEP (MM)	POWER (Watt)	WIND SPEED (MS)	AIR DELIVERY (cmm)	PKG
Bladeless Fan with Air Purifier	FF 1001	GLIDE	Bladeless	35	5.8	--	1

Ceiling Fan

CATEGORY	PRODUCT CODE	PRODUCT NAME	SWEEP (MM)	POWER (Watt)	SPEED (PRM)	AIR DELIVERY (cmm)	PKG
Super Premium Fans	FF 1101	F-WAVE	1200	35	350	220	1
	FF 1102	ELLA	1230	38	200	230	1
	FF 1103	URUS*	1200	40	330	220	1
	FF 1104	AERIS PRO	1200	32	350	220	2
	FF 1105	AERIS	1200	32	350	220	2
	FF 1106	LOFT	800	50	350	160	1
	FF 1107	STELLA	600	60	850	140	4
	FF 1108	GREZIA	1320	40	240	230	1
	FF 1109	BRISA	1230	38	200	230	1
	FF 1110	SILENT WAVE	1200	57	300	235	1
	FF 1111	AERIS ART	1200	32	350	220	1
Premium Fans	FF 2102	CASA BLDC	1200	35	350	225	2
	FF 2103	OLYMPIA	900	45	450	140	2
			1200	53	350	220	2
	FF 2104	AERO	900	45	450	140	4
			1200	53	350	220	4
	FF 2106	SOLIS	900	45	450	140	4
			1200	52	380	210	4
	FF 2107	CASA PLUS	900	44	450	140	2
			1200	52	350	225	2
	Decorative Fans	FF 3101	F-FLOW PRO	900	45	450	140
1200				52	390	210	4
FF 3102		AIR-1 PRO	900	45	450	140	4
			1200	52	400	210	4
			1400	60	290	250	4

Ceiling Fan

CATEGORY	PRODUCT CODE	PRODUCT NAME	SWEEP (MM)	POWER (Watt)	SPEED (RPM)	AIR DELIVERY (cmm)	PKG	
Standard Fans	FF 4101	AIR-1	900	45	450	140	4	
			1200	52	400	210	4	
			1400	60	290	250	4	
	FF 4102	FALCON SS	1200	52	380	210	4	
	FF 4103	F-FLOW	900	45	450	140	4	
			1200	52	390	210	4	
	FF 4104	VELO	1200	30	350	215	4	
	FF 4105	MENOR	600	65	850	100	4	
	FF 4106	YALE	120	5	370	22	4	
	FF 4107	NIMO	0	2	350	0	4	
				120	3		22	
				0	5		0	

Portable Fans

CATEGORY	PRODUCT CODE	PRODUCT NAME	SWEEP (MM)	POWER (Watt)	SPEED (RPM)	AIR DELIVERY (cmm)	PKG	
Table Fans	FF 5101	VAYU	400	58	1330	70	2	
	FF 5102	GUSH	400	110	2200	90	2	
	FF	NOOK	40	60	1350	72	2	
	5103	NOOK PLUS	0	120	2200	95	2	
Wall Fans	FF 5201	VAYU	400	58	1330	70	2	
	5104 FF 5202	GUSH	900	75	2400	70	2	
			400	110	2200	90	2	
	FF 5203	MAGNUM	450	95	1350	110	1	
	FF	NOOK	40	63	1350	72	1	
	5204	NOOK PLUS	0	120	2200	95	2	
Pedestal Fans	FF 5301	VAYU	400	58	1330	70	2	
	5302	GUSH	900	110	2200	90	2	
	FF 5401	F-SPIN	400	125	2200	105	1	
	FF 5402	MAGNUM	450	95	1350	110	1	
	FF 5403	THUNDER	500	140	1350	100	1	
	FF 5404	F SPIN-3	40	115	2200	110	1	
	FF 5405	THUNDER-3	0	145	1350	120	1	
	FF 5303	NOOK	50	60	1350	72	2	
	FF 5304	NOOK PLUS	0	120	2200	95	2	
	Personal Fans	FF 5501	GALE	400	75	2200	60	4
		FF 5601	TRI AIR	225	45	2500	25	4
		FF 5801	LUNA 2X2	400	80	1300	2400 (CMH)	1
FF 5901		SILO	0	150	1350	2250 (CMH)	1	

Portable Fans

CATEGORY	PRODUCT CODE	PRODUCT NAME	SWEEP (MM)	POWER (Watt)	WIND SPEED (MS)	AIR DELIVERY (cmm)	PKG
Personal Fans	FF 5701	HANDY GUST	150	35	5.5	--	1

Exhaust Fans

CATEGORY	PRODUCT CODE	PRODUCT NAME	SWEEP (MM)	POWER (Watt)	SPEED (RPM)	AIR DELIVERY (CMH)	PKG
Axial Fans	FF 6101	ZEST	150	22	1800	250	8
	FF 6102	ENOR	150	22	1800	250	8
	FF 6103	LUSH	100	18	2200	90	12
			150	22	1800	250	8
Ventilation Fans	FF 6201	VENTFLO	150	35	1350	280	6
			200	38	1300	550	4
			250	40	1250	750	4
	FF 6301	VENTI AIR	200	35	1350	200	4
Metal Exhaust Fans	FF 6401	EXFLO PLUS	150	40	2350	350	6
			225	70	2500	1050	4
	FF 6402	EXFLO	225	35	1350	750	4
			300	45	1350	1150	4

DELHI
166, Functional Industrial Estate,
Patparganj, DELHI - 110092

UTTAR PRADESH
J-48 & J-49, Sector-63, Noida,
Gautam Buddha Nagar,
Uttar Pradesh - 201301

92/190, 1st Floor, Bhaskar Complex,
Adjacent Hotel S.P. International
Gautam Buddha Marg,
LUCKNOW-226018

Khasra No. 6 KH, Plot No: 03,
Dehra MG Road, Opp: Coca Cola,
Dhaulana, Hapur (UP) - 245101.

NORTH



RAJASTHAN
C-76, Shastri Nagar,
Near Saboo School,
JAIPUR - 302016



SOUTH

TAMIL NADU
12/42, Taylors Road,
Kilpauk, CHENNAI - 600010

KERALA
Kudiyirickal Towers, First Floor,
Palarivattom, Edappally Road,
ERNAKULAM - 682025

KARNATAKA
28, Off Mysore Road
Suder Industrial Estate
New Timber Yard Layout
BENGALURU - 560026

GOA
121, Nagarathpet Main Road,
Near Kalamma Temple,
BENGALURU - 560002

WEST BENGAL
Flat No. 2F, Crescent Tower,
229 AJC Bose Road, KOLKATA - 700020

Plot No. 1369, Sankrail Industrial Park
Dhulagarh, Dist Howrah
KOLKATA - 711302

30, Sevok Road, Santdeep Building
2nd Floor, SILIGURI - 734001

BIHAR
JAK, Pratap Nagar,
Jakariyapur, PATNA - 800001

Jindal House Building, P. K Sahi Lane, 5th Floor
S. P Verma Road, PATNA-800001

JHARKHAND
Plot No. 2072, Near MS Dhoni Farm House,
Vill-Simaliya, PS-Ratu,Daladili Chowk,
RANCHI - 835222

ASSAM
Dhiraj Tumung Compund,
Dag No. 102, Pamohi - DPS Road
GUWAHATI - 781035

ODISHA
No.: C/3, Old Industrial Estate
Jagatpur, Cuttack, Odisha - 754021

WEST



GUJARAT
722, Khatri Pole, Opp.
Pada Pole, Gandhi Road,
AHMEDABAD-380001

First Floor, Shop No. 82-1,
Paras Chambers, JEAN Compound,
Surendranagar - 363002

MAHARASHTRA
Gala No. 9 & 10, Blue Bell Imperial
Manas Industrial Hub,
Opp. Chinchpada, Valiv Road,
Vasai East, PALGHAR - 401208

EAST



BALAR MARKETING PVT. LTD.
217, Functional Industrial Estate,
Patparganj, DELHI - 110092

BALAR MARKETING PVT. LTD.
J-48 & J-49, Sector-63,
Noida, Gautam Buddha Nagar ,
Uttar Pradesh - 201301

FYBROS MODDULAR PVT. LTD.
205, 2nd floor,
Orbit Industrial Estate,
Chincholi Bunder Road,
Malad (W) MUMBAI- 400064

BALAR MARKETING PVT. LTD.
12/42, Taylors Road,
Kilpauk, CHENNAI - 600010

H.O.



Our Footprints Across India



Divya Electricals
Chennai

Contact:

9841260168

96009984212

044-4216 5795

divyaelectricalschennai@yahoo.co.in



SCAN this QR-code from
your smart phone to
visit our website

Call

1800-270-6334
(Customer Support)

My Fybras App



7070706737
(Say "Hi" for quick connect)

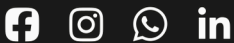

The intellectual property of Balar Marketing Pvt. Ltd. is safeguarded by copyright. Reproduction or printing of any portion of this catalogue is strictly prohibited without the explicit consent of Balar Marketing Pvt. Ltd. Our patents, trademarks, and designs are legally protected. Any infringement is subject to prosecution. Imitation of graphics is considered a punishable offense. The brand identity, concept, and design are exclusive to Balar Marketing Pvt. Ltd.

Terms & Conditions:

Warranty is applicable to Fybras products according to Fybras's warranty policy. Continuous design and product development are routine practices at Fybras, so data in this catalogue may change without prior notice. Customers are advised to check current data before purchasing any product.

Images/colours used in the catalogue are strictly for representational purposes only. Actual product/colour may vary due to product improvements, innovations and printing limitations.